



District heating pipe technology

www.rkinfra.com

Table of contents

Area of application District heating pipe technology	3
District heating technology	4-9
District heating technology pipe system FibreFlex/ FibreFlex PRO/HeatFlex	10-11
Technical Description FibreFlex	12
Measurements FibreFlex	13
Heat loss calculations FibreFlex	14
Heat loss data FibreFlex	15
Temperature and Pressure limit FibreFlex	16
Operational duration FibreFlex	17
Technical Description FibreFlex PRO	18
Measurements FibreFlex PRO	19
Heat loss calculations FibreFlex PRO	20
Heat loss data FibreFlex PRO	21
Temperature and Pressure limit FibreFlex PRO	22
Operational life time FibreFlex PRO	23
Technical Description HeatFlex	24
Measurements HeatFlex	25
Heat loss calculations HeatFlex	26
Heat loss data HeatFlex	27
Temperature and Pressure limit HeatFlex	28
Operational duration HeatFlex	29
Pressure loss FibreFlex - Planning	30-33
Pressure loss HeatFlex - Planning	34-37
Project planning - Planning	38-41
Laying/ Storage	42
Storage types	43-45
Laying	46
Trench profile	47
Connection technology	48-51
Pipe straightner	52-53
Sleeve system	54-55
Wall sealing labyrinth ring	56-59
Wall sealing ring	60-63
House entry bends	64-65
Non-insulated bend with radon	66-67
Checklist Material for connection	68-71
Pressure and Tightness test/Protocol for pressure test	72-73
Questionnaire	74-75
Norms and Guidelines	76-77
Legal notices and safety information	78-79

Area of application

District heating technology

The pipe system of **RK Infra** has been specifically developed for local and district heating networks. However, these pipes are also highly suitable for industry, agriculture and cold supply and geothermal services. A long lifespan, terrific insulating properties and a diverse molding program make these products exceptional.

RK Infra offers district heating pipes, whose top products in the **FibreFlex** and **HeatFlex Family** effectively transport heat thanks to their flexibility and insulation.

This connection system allows a laying without the need for thermal expansion. Because of the pipe's flexibility, the adjustment of the route when crossing supply lines and obstacles is expected to be problem-free.

The delivery in coils furthermore allows for extremely long lengths and mostly prevents the need for many connection points.

Next to the normal **FibreFlex**- and **HeatFlex**-Pipe, we offer a further reduction in an already low temperature loss through the PLUS-alternative with an even thicker isolation.

All pre-insulated flexible district heating pipes from **RK Infra** are exceptionally suitable for the introduction of local and district heating networks with temperature with maximum 115°C and an operating pressure of maximum 16 bar. These pipes are specifically conceptualized for the underground.

Detailed information about the district heating system of **RK Infra**, all the key facts about our accessories and the laying and planning of a heat network can be found on the following pages.

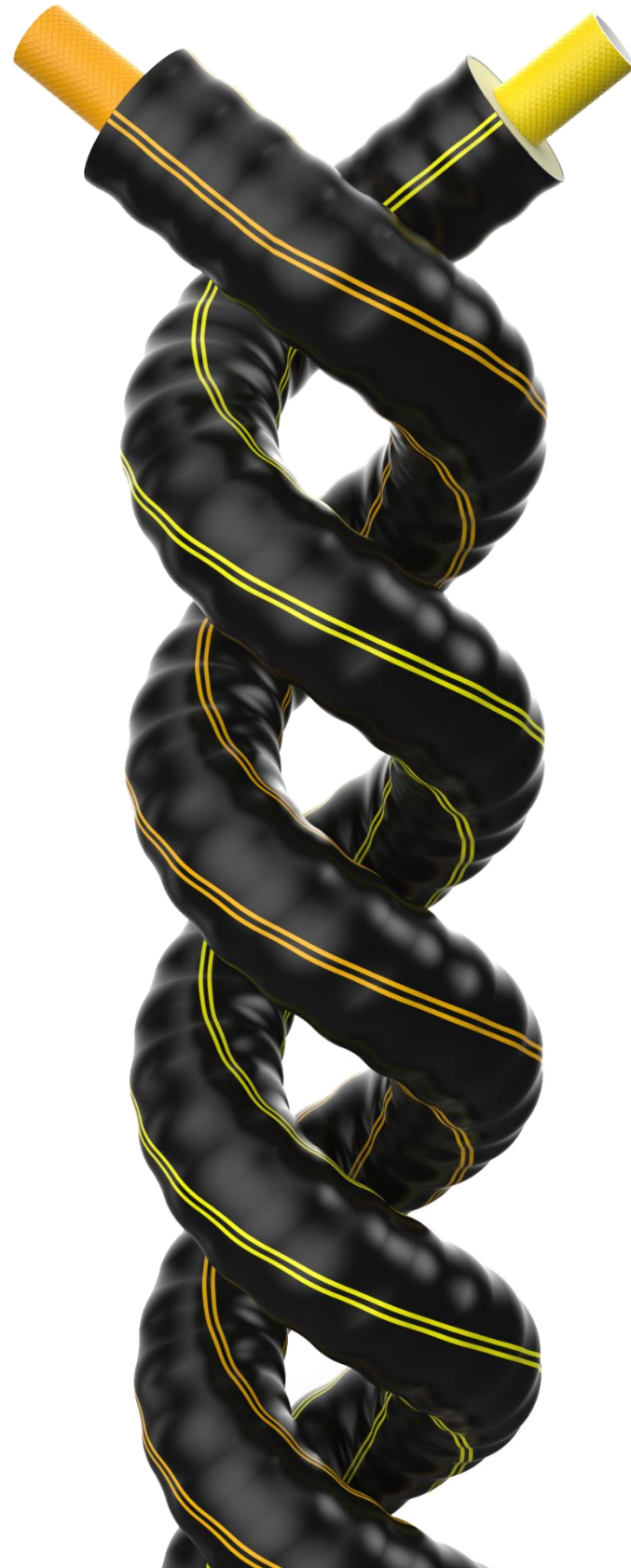

FibreFlex/HeatFlex District heating technology

HEAT FROM THE LOCATION

FibreFlex and HeatFlex: The flexible heating pipe transports heat with its effective isolation. This tightly-bonded system that has a PE-LLD outside jacket makes laying the pipe very simple. A successful change of your heat network is allowed by a low heat loss of various pipe types which are suitable for many operation requirements.



Abb. 1:
up: **FibreFlex PRO**-pipe; middle: **FibreFlex**-pipe;
under: **HeatFlex**-pipe

PLANNING

Thanks to the flexibility of the pipe, the shortest way can be chosen when routing. There, the **FibreFlex/HeatFlex** pipes are delivered to the construction sites in coils. The connection places in the soil are therefore minimized through the larger delivery lengths! This way, the pipe trenches can be dug much narrower and the underground digging costs can be reduced.

The district heating system does not only lower the construction time, but also improves coordination at the construction site!

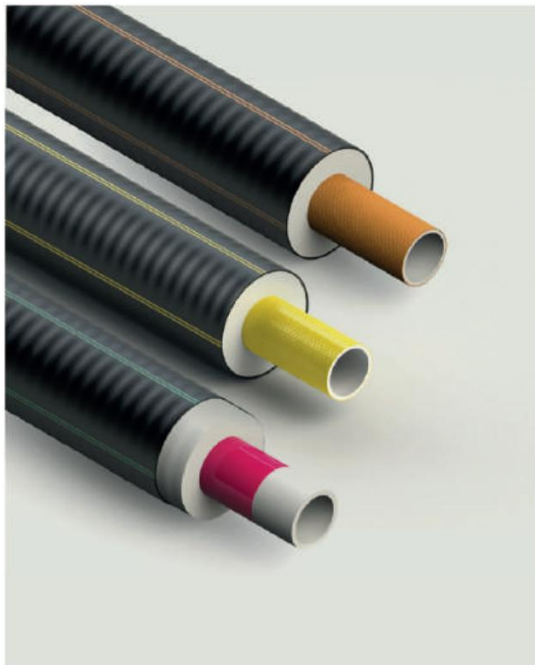
LAYING

Through **FibreFlex/HeatFlex** it is possible to easily and spontaneously adapt to the current construction situations. All unexpected obstacles which emerge in an open trench can be passed without a lot of commotion or extra effort.



Abb. 2: Laying in practice

The **RK Infra** heat pipe does not need fixed points thanks to the bonding system between the medium pipe, PUR-foam and the jacket pipe. This way, the need for expansion bends or a static layout can be avoided, unlike with steel lines!

SLEEVE TECHNOLOGY

The new **HeatClick** sleeve system from **RK Infra** accommodates for a quick and easy installation thanks to the innovative system. The click system is especially advantageous for construction sites: the strongly- and self-bonded pipes can be easily connected with the **HeatClick** tension-free and weather independently, as the time-consuming glue, screwing and shrinking are no longer necessary.



Abb. 3: The assembly process of the **HeatClick** Sleeve (locking ring)

The safe connection technology offers the highest thermal insulation properties through the usage of the polyurethane foam. The sealing rings allow for the pipe's high movement flexibility while also insulating the space between the pipe and the sleeve.



Abb. 4: The assembly process of the **HeatClick** Sleeve (Sleeve sealing ring)

The assembly is quick, easy and tool-free. Elements of half shells make the positioning of them easier, as they just need to be clicked together and locked into their final position. A seal which is already glued in the lower sleeve of the half shell guarantees a safe, long-lasting and waterproof experience.



Abb. 5: The assembly process of the **HeatClick** Sleeve (clip)

The **HeatClick** Sleeve are available in the I-, L-, and T- Sleeves in two different sizes, with the pipe diameter reaching from 76 mm to 202 mm.



Abb. 6: Moldings **HeatClick**

HeatClick-Sleeve	Jacket pipe
small	76-142
big	76-202

Materials	
Half shell	} ABS-Plastic
Locking ring	
Clip	
Sealing plug	
Sleeve sealing ring	EPDM

Tab. 1: Dimension & Material **HeatClick**

FibreFlex/HeatFlex District heating technology

PUR SLEEVE FOAM

The insulation of the **RK Infra HeatClick**-sleeves at the construction site requires a liquid PUR foam. The foam gets spread out evenly throughout the sleeve and after a defined time fills out the entire sleeve seamlessly. The cyclopentane foam is semi-flexible as well as proves to have a very high insulating ability.

The mounting foam of the **RK Infra HeatClick**-sleeves consists of two following components: Isocyanat (component A) und Polyol (component B).

Technical data components A (brown)

Burning point	> 200 °C
Vapor pressure [20°C]	1 hPa
Density p [20°C]	1238 kg/m ³

Technical data components B (gelb/braun)

Burning point	-17 °C
Vapor pressure [20°C]	102 hPa
Density p [20°C]	1060 kg/m ³

Tab. 2: Foam components technical data

The mixing ratio of both contains:
Isocyanat – 146g : Polyol – 100g

The mixing of both chemicals leads to a chemical process which creates PUR foam.

Handling:

Pour the contents of bottle B into bottle A. Screw the pointed cap of bottle A and shake the bottle for around 20 seconds (25°C). The relevant values for other temperatures are as follows in the next table:

Temperature	Mixing time	Processing time
25 °C	20 Sek.	30 Sek.
20 °C	25 Sek.	40 Sek.
15 °C	40 Sek.	50 Sek.

Tab. 3: PUR-foam components processing time

Cut the top of the cap and pour the liquid of bottle A into the insulation hole.

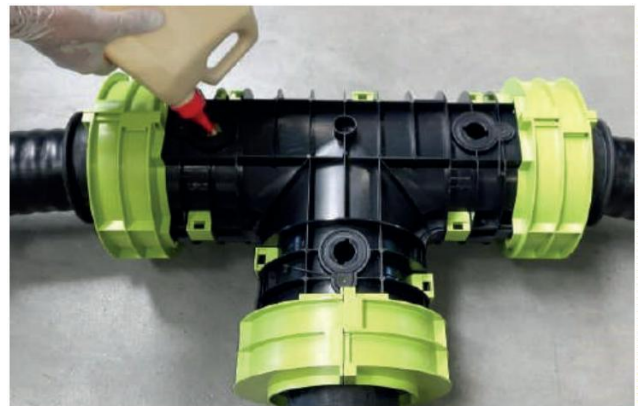

The mixture will turn into a semi-flexible and firm PUR foam. This process begins

Technical data components at 20°C

Mixing ratio A:B in g	146 : 100
Starting time	54 Sek.
Pipe density p [Kern]	> 60 kg/m ³
Closed cells	90 %

Tab. 4: PUR foam technical data

Optimal deployment temperature: 20-25 °C.

Optimal sleeve and line pipe surface

temperature: 15-45 °C.

Optimal storage:

During the processing procedure, it is important to wear protecting glasses and gloves.



Abb. 7: Storage and processing of the sleeve foam.

CONNECTION TECHNOLOGY

RK Infra offers press connectors with compression sleeves technique as well as clamp connectors. These connection technologies make a weather-independent assembly possible.

Because the pressing connectors come into use in areas of PN 6, PN 10 and P16, the usage of the clamp connectors is therefore limited to the nominal pressure level of PN 6.



Abb. 11: compression fitting with male thread incl. compression sleeve



Abb. 8: compression fitting coupling incl. compression sleeve



Abb. 12: compression fitting with welding ends incl. compression sleeves



Abb. 9: compression fitting elbow coupling 90° incl. compression sleeve



Abb. 13: clamp fitting with male thread for exclusively PN 6 pipes



Abb. 10: compression fitting T-piece coupling incl. compression sleeve

Materials

Press connectors PN 6	Brass rotgus
Press connectors PN 6 transitions to steel	Steel
Press connectors PN 10/PN 16	Steel
Clamp connectors PN 6	Brass

Tab. 5: Materials connection technology

FibreFlex/HeatFlex District heat technology

PRE-INSULATED T-PIECES

T-Press fittings cannot be isolated with the **HeatClick-sleeve system** because of their measurements. This is why the **RK Infra FibreFlex/ HeatFlex system** offers pre-insulated straight T-piece elements which are available in the corresponding dimensions. The length of a T-piece is 1,00 m in length and 0,50 in width. The connection fittings are fitted at the factory and are 1,50m to 1,80m, depending on if the dimensioning of the DUO sliding sleeves are included. The connection fittings are already factory pre-mounted, and the compression sleeves are included in the delivery.



Abb. 14: Pre-insulated T-piece

Materials	
Medium pipe	Steel
Insulating material	PUR-foam
Outer jacket	PE-HD glatt

Tab. 6: Materials pre-insulated T-pieces

SHUT-OFF VALVE

Factory-made pre-insulated **RK Infra shut-off valve** with a ball valve are made in UNO or DUO design for a direct ground laying. The corresponding transitions are already preinstalled for the connection on the pipeline. The necessary compression sleeves are there as well. The length of a shut-off valve of a UNO pipe is between 1,50m to 1,80m, while the length ranges from 2,00m to 2,50m when it comes to shut-off valves of DUO pipes.

Laying the shut-off valves at a greater depth is only possible when using a spindle extension. The connector for a spindle connection is available.



Abb. 15: Pre-insulated shut-off valve

Materials	
Medium pipe	Steel
Insulating material	PUR-foam
Outer jacket	PE-HD glatt

Tab. 7: Materials pre-insulated shut-off valve

UNO TO DUO TRANSITION ASSEMBLY

The pre-insulated **RK Infra** UNO to DUO transition assembly will be set up for the transition between two UNO pipes to one DUO pipe.

The length of the transition assembly is 1,80 m. The medium pipe diameter of between 25mm to 90mm will be covered.

The connection of the transition assembly to the piping system is the same as with all other **RK Infra** fittings.

The **RK Infra HeatClick**-sleeves come into use when connecting the outside jacket.

When laying, it is important to take care that the main and return line are assigned correctly and that there is no mix-up between the two before the installation.



Abb. 16: UNO to DUO transition assembly

Materials	
Medium pipe	Steel/PE-Xa
Insulating material	PUR-foam
Outer jacket	PE-HD smooth

Tab. 8: Materials transition assembly

House entry bends

When creating district heating systems in already built or newly built locations and areas, it often happens that the basements of these buildings are inaccessible. For these cases, the pipe system from **RK Infra** offers house entry bends, used for connecting the buildings to the floor plates without the need for entering a basement. The bends are produced in the length of 1,10 m x 1,60 m. They are available as UNO as well as DUO pipes.



Abb. 17: House entry bends

Materials	
Medium pipe	Steel/PE-Xa
Insulating material	PUR-foam
Outer jacket	PE-HD smooth

Tab. 9: Materials house entry bend

FibreFlex/HeatFlex District heating pipe system

The pre-insulated pipe system from **RK Infra** consists of two different pipe types. Both have a seamless and corrugated PE-LLD outer jacket. The extraordinary insulation conductivity is assured through the usage of a FCKW-free polyurethan foam. For a further reduction in the already low heat loss of the normal **FibreFlex/HeatFlex** pipe, we offer a PLUS alternative with a thicker isolation. Both can be delivered as single (UNO) and double (DUO) pipes, depending on availability. The gravitating difference, however, lies in the way the medium pipe is made.

The pipes from the **FibreFlex-Family** transport heat through a PE-Xa medium pipe which is strengthened through aramid fibres. The advantage of this alternative lies in a low heat loss, longer durability and a high operating pressure compared to the standard type. The **FibreFlex PRO** pipe also brings a higher maximal temperature and a longer duration thereof. The standard type **HeatFlex** has a normal PE-Xa medium pipe and is better for the rest of applications in district heating.



Abb. 18:

DUO HeatFlex Outer jacket and insulation

HEAT INSULATION PN 10, PN 16 UND PN 6

Heat insulation

PUR-foam:	FCKW-free, cyclopentane, semiflexible polyurethan foam, HBCD-free
Thermal conductivity	$\leq 0,021$ W/mK
Density:	> 60 kg/m ³
Closed cells:	≥ 90 %
Water absorption after 24h:	≤ 10 %

Tab. 10: Outer jacket characteristics

The pipe systems are insulated with polyurethan foam (PUR), which is why the energy density is high while the heat loss remains low.

JACKET PIPE PN 10, PN 16 UND PN 6

Jacket pipe

Material:	Polyethylene lower thickness (PE-LLD) corrugated, seamlessly extruded
Function:	Protection from mechanical influence, humidity and UV.
Thermal conductivity	0,33 W/mK
Density:	928 – 938 kg/m ³
Crystallite melting range:	105 – 110 °C

Tab. 11: Pipe insulation characteristics

The jacket is made from a highly flexible PE-LLD. The medium pipe is strongly connected with the outer jacket over the insulation. This is strongly resistant against chemical bounds. Furthermore, the pipe systems **FibreFlex** and **HeatFlex** are the best for ground laying.

PIPES

This connection system makes a laying without the consideration of thermal expansion possible. The bendability of the pipe allows for a problem-free adjustment of the route when crossing supply lines in case of obstacles. The delivery in coils up to 770m enables very long routes without connection points. For a further reduction in an already low heat loss level of the HeatFlex pipe, we offer a PLUS alternative with thicker isolation.

For the Plus-insulated FibreFlex there is also a Plus₂ Alternative with an even higher isolating factor. In the 2a Table the purpose of use after the heat- and pressure resistance is shown.

COILS

Jacket pipe outside diameter [mm]	Max. length of coils [m]		Coils weight Weight table Side 13 and 19 [kg]
	Coil diameter 2,8m	Coil width 1,2m	
76	770		693 - 770
91	550		671 - 737
111	410		689 - 808
126	300		624 - 780
142	225		585 - 763
162	149		507 - 760
182	86		366 - 548
202	80		426 - 555
225	150		

Tab. 12: Maximum coil length and weight after the jacket pipe diameter

TEMPERATURE RESISTANCE, PRESSURE RESISTANCE AND LIFETIME

	60°C und SF1,5		70°C und SF1,5		80°C und SF1,5		85°C und SF1,3		Max. Temp. (gleitend) [°C]	incident temperature [°C]
	[bar]	[Years]	[bar]	[Years]	[bar]	[Years]	[bar]	[Years]		
PE-Xa Medium pipe PN6	7,8	100	6,9	95	6,3	32	6,9	19	95	100
FibreFlex PN10	14,0	>100	12,0	100	10,0	50	9,0	30	95	110
FibreFlex PRO PN16	22,5	>100	20,0	100	18,4	50	16,9	50	115	125

Tab. 12a: Comparison of RK Infra pipe systems; (SF=safety factor)



Abb. 19: FibreFlex/HeatFlex stored coils

TECHNICAL DESCRIPTION



MEDIUM PIPE FIBREFLEX

This pre-insulated and flexible plastic pipe system with an integrated, tightly strengthened polyethylene (PE-Xa) and a PUR heat isolation is perfect for local and district heating networks with temperature reaching up to 95 °C and an operating pressure up to 10 bar. The pipe system is created for ground laying. The medium pipe is made from cross-linked polyethylene PE-Xa (DIN16892). This material, thanks to its physical properties, is ideal for thermal and mechanical services.

The FibreFlex medium pipe is strengthened by a tight braid of amide fibres. The use of these fibres enables a higher operating pressure without having to enlarge the pipe's wall thickness. Next to the standard plastic pipe system, the FibreFlex pipe, which has a median pressure of 10 bar, can be transported at a constant temperature from 80°C.

Thanks to its wall thickness, the FibreFlex pipe is flexible and has a very high isolation in comparison to the conventional PEX pipe system PN 6. The insulation of the otherwise same outer diameter of the entire district heating pipe will be improved through the smaller outer diameter of the medium pipe. The medium pipe made out of PE-Xa is easy to process despite of corrosion- and maximum chemical resistance. Simultaneously, this pipe is free from harmful substances and is therefore environmentally friendly. In order to avoid oxygenation in the system, an organic oxygen diffusion barrier (EVOH DIN 4726) is applied to the medium pipe.

CONSTRUCTION FIBREFLEX

This drawing illustrates the construction of the FibreFlex pipe:



1. PE-Xa Medium pipe
2. Adhesive layer
3. Aramid fibre mesh
4. intermediate layer incl. oxygen diffusion barrier
5. medium pipe outer jacket
6. flexible polyurethan foam (PUR)
7. Casing

Data overview FibreFlex Medium pipe

Material:	webbed Polyethylene PE-X, strengthened with amide fibres; base material PE-Xa; DIN 16892
Net:	Peroxid (procedure) PE-Xa
Density:	938 – 940 kg/m ³
Tear strength:	20 °C: 26 – 30 N/mm ² ; 80 °C: 18 – 20 N/mm ²
Special thermal expansion:	0,175 mm/mK
Elasticity-Modul:	600 N/mm ²
Crystallite melting range:	130 – 136 °C
Surface roughness k:	0,007 mm
Characteristics:	A very good chemical consistency after DIN 8075
Bonding agent:	PE-modified, stabilised for heat
Oxygen diffusion barrier	Organic EVOH-yellow, stabilised for heat, < 0,10 g/m ³ d
Area of application:	80 °C (constant temp.) 10 bar; t max. 95 °C (sliding)

Tab. 13: Characteristics FibreFlex medium pipe

MEASUREMENTS

The **RK Infra FibreFlex** is available as an UNO- or DUO-pipe
 The available pipe dimensions with the corresponding measures are listed on the following table.

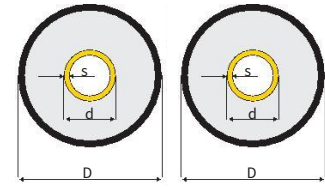

FibreFlex UNO

Typ	DN	Mediumrohr Ø [mm]	Ummantlung Ø [mm]	Min. Biegeradius	Gewicht	Maxi-Coil
25/76	20	25,0 x 2,2	76	0,70	1,06	570
25/91 Plus	20	25,0 x 2,2	91	0,90	1,26	570
25/111 Plus ²	20	25,0 x 2,2	111	0,90	1,70	410
32/76	25	32,0 x 2,5	76	0,70	1,14	570
32/91 Plus	25	32,0 x 2,5	91	0,90	1,34	570
32/111 Plus ²	25	32,0 x 2,5	111	0,90	1,80	410
40/91	32	40,0 x 2,8	91	0,90	1,90	570
40/111 Plus	32	40,0 x 2,8	111	0,90	1,90	410
40/126 Plus ²	32	40,0 x 2,8	126	1,00	2,10	300
50/111	40	47,6 x 3,6	111	0,90	1,97	410
50/126 Plus	40	47,6 x 3,6	126	1,00	2,24	300
63/126	50	58,5 x 4,0	126	1,00	2,38	300
63/142 Plus	50	58,5 x 4,0	142	1,10	2,73	225
75/142	65	69,5 x 4,6	142	1,10	2,94	225
75/162 Plus	65	69,5 x 4,6	162	1,20	3,47	150
90/162	80	84,0 x 6,0	162	1,20	4,02	150
90/182 Plus	80	84,0 x 6,0	182	1,30	4,72	86
110/162	100	101,0 x 6,5	162	1,20	4,26	150
110/182 Plus	100	101,0 x 6,5	182	1,30	4,99	86
110/202 Plus ²	100	101,0 x 6,5	202	1,30	5,38	80
125/182	100	116,0 x 6,8	182	1,30	5,11	86
125/202 Plus	100	116,0 x 6,8	202	1,40	6,02	80
125/225 Plus ²	100	116,0 x 6,8	225	1,60	7,10	150
140/202	125	127,0 x 7,1	202	1,40	6,30	80
140/225 Plus	125	127,0 x 7,1	225	1,60	7,50	150
160/225	150	144,0 x 7,5	225	1,60	7,68	150

Notice: When making calculations, keep in mind that two UNO tubes are required.

Tab. 14: Measurements FibreFlex UNO

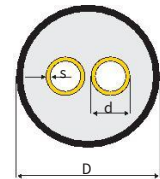

FibreFlex DUO

Typ	DN	Mediumrohr Ø [mm]	Ummantlung Ø [mm]	Min. Biegeradius	Gewicht [kg]	Maxi-Coil
25+25/91	20	25,0 x 2,2 / 25,0 x 2,2	91	0,70	1,4	570
25+25/111 Plus	20	25,0 x 2,2 / 25,0 x 2,2	111	0,90	1,8	410
25+25/126 Plus ²	20	25,0 x 2,2 / 25,0 x 2,2	126	0,90	2,2	300
32+32/111	25	32,0 x 2,5 / 32,0 x 2,5	111	0,90	1,9	410
32+32/126 Plus	25	32,0 x 2,5 / 32,0 x 2,5	126	0,90	2,3	300
32+32/142 Plus ²	25	32,0 x 2,5 / 32,0 x 2,5	142	1,00	2,7	225
40+40/126	32	40,0 x 2,8 / 40,0 x 2,8	126	0,90	2,6	300
40+40/142 Plus	32	40,0 x 2,8 / 40,0 x 2,8	142	1,00	2,9	225
40+40/162 Plus ²	32	40,0 x 2,8 / 40,0 x 2,8	162	1,20	3,3	150
50+50/162	40	47,6 x 3,6 / 47,6 x 3,6	162	1,20	3,6	150
50+50/182 Plus	40	47,6 x 3,6 / 47,6 x 3,6	182	1,30	4,3	86
63+63/182	50	58,5 x 4,0 / 58,5 x 4,0	182	1,30	4,5	86
63+63/202 Plus	50	58,5 x 4,0 / 58,5 x 4,0	202	1,40	5,3	80
75+75/202	65	69,5 x 4,6 / 69,5 x 4,6	202	1,40	5,7	80
75+75/225 Plus	65	69,5 x 4,6 / 69,5 x 4,6	225	1,60	6,6	150
90+90/225	80	84,0 x 6,0 / 84,0 x 6,0	225	1,60	7,3	150

¹ until 150 m on the special coil D 2,9 m / B 2,4 m

Tab. 15: Measurements FibreFlex DUO

HEAT LOSS CALCULATIONS



HEAT LOSS CALCULATIONS

The heat loss of a FibreFlex UNO- or DUO-pipe is calculated on the basis of the following requirements:

Calculation basics	
Laying method FibreFlex UNO	2m PIPE layed pro. route meters
Laying method FibreFlex DUO	1m pipe layed pro track meters
Pipe distance:	a= 0,10m
Cover height:	H= 0,80m
Soil temperature:	T _E = 10 °C
Conductivity of the soil	λ _E = 1,0 W/mK
Conductivity of the PUR foam	λ _{PU} = 0,0210 W/mK
Conductivity of the PEX pipe	λ _{PEXa} = 0,38 W/mK
Conductivity of the PE jacket	λ _{PE} = 0,33 W/mK

Heat loss in practice

$$Q = U \cdot [T_B - T_E] \text{ [W/m]}$$

$$U = \text{Wärmedurchgangskoeffizient [W/mK]}$$

$$T_B = \text{Mittlere Betriebstemperatur [°C]}$$

$$T_E = \text{Mittlere Erdreichtemperatur [°C]}$$

$$VL = \text{Vorlauf}$$

$$RL = \text{Rücklauf}$$

Tab. 16:
Calculation basics for heat loss calculations FibreFlex



Abb. 20: Pipe trench UNO-pipe



Abb. 21: Pipe trench DUO-pipe

EXAMPLE HEAT LOSS CALCULATION FibreFlex 75/142

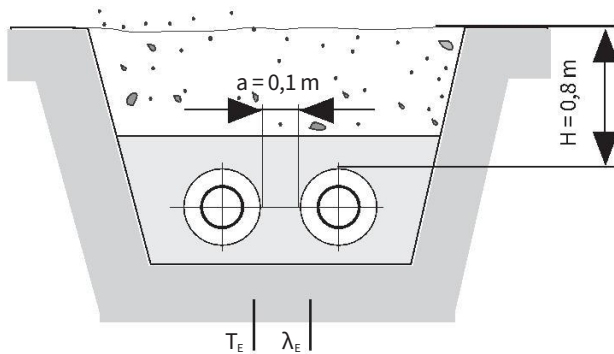
Flow temperature	80 °C
Return temperature	60 °C
Middle operational temperature	70 °C
Heat loss from the table	10,36 W/m
Heat loss from one route meter	10,36 W/m * 2 = 20,72 W/m

The value can be taken directly from the table for DUO cables.

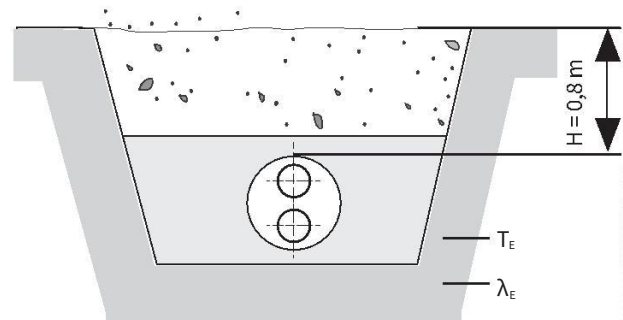
HEAT LOSS DATA

Based on the calculation schemes the heat loss results of the FibreFlex pipe UNO und DUO can be seen on the following table:

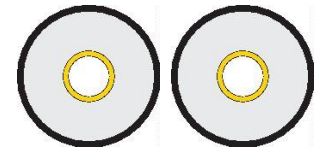

FibreFlex UNO

UNO PN10	U-Wert [W/mK]	Betriebstemperatur T [°C]		
		80°C	70°C	60°C
25/76	0,1129	15,81	13,55	11,29
25/91 PLUS	0,0973	13,62	11,67	9,73
32/76	0,1434	20,08	17,21	14,34
32/91 PLUS	0,1190	16,67	14,28	11,90
40/91	0,1492	20,89	17,91	14,92
40/111 PLUS	0,1213	16,98	14,55	12,13
50/111	0,1442	20,19	17,31	14,42
50/126 PLUS	0,1264	17,70	15,17	12,64
63/126	0,1577	22,08	18,93	15,77
63/142 PLUS	0,1377	19,28	16,52	13,77
75/142	0,1680	23,51	20,15	16,80
75/162 PLUS	0,1440	20,15	17,28	14,40
90/162	0,1813	25,38	21,76	18,13
90/182 PLUS	0,1562	21,87	18,74	15,62
110/162	0,2432	34,05	29,19	24,32
110/182 PLUS	0,2001	28,01	24,01	20,01
125/182	0,2536	35,50	30,43	25,36
125/202 PLUS	0,2103	19,44	25,24	21,03
140/202	0,2460	34,44	29,52	24,60
140/225 PLUS	0,2050	28,70	24,60	20,50
160/225	0,2550	35,70	30,60	25,50

Bear in mind: In order to obtain the heat loss of a route meter, the value [W/m] must be multiplied by a factor of 2 for UNO pipes!

Tab. 17: Heat loss FibreFlex UNO

FibreFlex DUO

DUO PN10	U-Wert [W/mK]	Betriebstemperatur T [°C]		
		80°C	70°C	60°C
25+25/91	0,1821	12,75	10,93	9,11
25+25/111	0,1395	9,76	8,37	6,97
32+32/111	0,1937	13,55	11,62	9,68
32+32/126	0,1599	11,20	9,60	8,00
40+40/126	0,2206	15,44	13,23	11,03
40+40/142	0,1788	12,52	10,73	8,94
50+50/162	0,1866	13,06	11,20	9,33
50+50/182	0,1580	11,06	9,48	7,90
63+63/182	0,2116	14,81	12,70	10,58
63+63/202	0,1773	12,41	10,64	8,87
75+75/202	0,2353	16,47	14,12	11,76
75+75/225	0,1928	13,49	11,57	9,64
90+90/225	0,2781	19,47	16,69	13,91

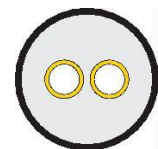

Tab. 18: Heat loss FibreFLEX DUO

TEMPERATURE, PRESSURE, SERVICE LIFE



TEMPERATURE AND PRESSURE LIMITS

Depending on a constant operating temperature and operating time, the values in the following table are valid for the **RK Infra FibreFlex** pipe.

The permissible operating pressures under the respective operating temperatures can be seen from the following table are based on the safety factor according to ISO 15875-2

Druckbegrenzung von FibreFlex PN10 (10bar)						
Betriebs-temperatur	Sicherheits-faktor	1 Jahr	5 Jahre	10 Jahre	25 Jahre	50 Jahre
10°C	1,5	23,6	23,2	23	22,8	22,6
20°C	1,5	20,9	20,5	20,4	20,1	20
30°C	1,5	18,5	18,2	18,1	17,9	17,7
40°C	1,5	16,5	16,2	16,1	15,9	15,7
50°C	1,5	14,7	14,4	14,3	14,1	14
60°C	1,5	13,1	12,9	12,8	12,6	12,5
70°C	1,5	11,8	11,5	11,4	11,3	11,2
80°C	1,5	10,5	10,3	10,2	10,1	-
90°C	1,3	11,2	10,9	10,8	-	-
95°C	1,0	11,4	11,1	11	-	-

Tab. 19: according to OFI ZG 200-2 technical specifications have to meet the safety factor 1,5 for design temperatures, 1,3 for maximum service temperatures and 1 for incidents (+110°C)

The minimum requirements for long-term behaviour according to the specifications of DIN 16892 have been met.

OPERATIONAL LIFETIME with the Miner's rule RK Infra FibreFlex

Running heating networks are used over the year with different flow and return temperatures T to T_1 to T_n . The given operational duration (D) of FibreFlex pipes can be calculated through the Miner's rule ISO 13760.

OPERATIONAL DURATION CALCULATION

$$D = \left(\frac{f_1/8760}{D_1} + \frac{f_2/8760}{D_2} + \dots + \frac{f_n/8760}{D_n} \right)^{-1}$$

- D Betriebsdauer in Jahren beim Betrieb mit wechselnden Temperaturen zwischen T_1 bis T_n
- D_1 bis D_n Betriebsdauer in Jahren beim Betrieb mit konstanter Temperatur T_1 bis T_n
- f_1 bis f_n Anteilige jährliche Betriebsstunden bei Betrieb mit Mediumtemperatur T_1 bis T_n

EXAMPLE FOR CALCULATING HEAT LOSS

The basis is a typical temperature in heating networks over a year with flexible operation:

Main pipeline seasonally	70 °C - 90 °C
Return pipeline	50 °C - 55 °C
Operational pressure	9 bar
1 year	365 days = 8760 h

Temperature	Service hours	Operational time (Pressure)
$T_1 = 60$ °C	$f_1 = 0$ h	$D_1 = 100$ years (14,0 bar)
$T_2 = 65$ °C	$f_2 = 0$ h	$D_2 = 100$ years (13,0 bar)
$T_3 = 70$ °C	$f_3 = 3528$ h	$D_3 = 100$ years (12,0 bar)
$T_4 = 75$ °C	$f_4 = 840$ h	$D_4 = 75$ years (11,0 bar)
$T_5 = 80$ °C	$f_5 = 3720$ h	$D_5 = 50$ years (10,0 bar)
$T_6 = 85$ °C	$f_6 = 504$ h	$D_6 = 30$ years (9,0 bar)
$T_7 = 90$ °C	$f_7 = 168$ h	$D_7 = 20$ years (9,0 bar)
$T_8 = 95$ °C	$f_8 = 0$ h	$D_8 = 10$ years (8,9 bar)

Service life (D) calculated according to ISO 13760 based on the values according to OFI ZG 200-2: 60 years

TECHNICAL DESCRIPTION



MEDIUM PIPE FIBREFLEX PRO

The pre-insulated and flexible pipe system with a medium pipe made out of and strengthened by cross-linked fibres of polyethylene (PE-Xa) as well as a PUR heat isolation is perfect for deployment in district heating networks with temperatures reaching up to 115°C and an operating pressure from 10 to 16 bar. **FibreFlex PRO** combines the advantages of a flexible pipe system with service characteristics of KMR steel pipe system, which makes it a very innovative and affordable alternative. The pipe system is created for ground laying. The medium pipe consists of cross-linked polyethylene PE-Xa (DIN16892). This material is ideal for thermal and physical services, thanks to its physical properties. The **FibreFlex PRO** medium pipe is strengthened with tightly bound aramid fibres. The deployment of these fibres allows for a higher operating pressure without needing to enlarge the pipe's wall thickness. Next to the standard option **FibreFlex Pro PN 10**, we also offer the **FibreFlex PRO PN 16**, which has an even stronger aramid fibre braid. Contrastingly to the standard plastic pipe system, it is possible to transport the **FibreFlex PRO PN 10** pipe at its constant temperature from 95°C, keeping in mind that the median of operating pressure of the pipe is 10 bars. The same is also possible with the **FibreFlexPRO PN 16**, however at 16 bars instead of 10. The higher maximum temperature of 115 °C or the constant temperature of 95 °C is achieved through using high-temperature adhesives in the adhesion layers, contrary to the conventional PEX pipe systems. Otherwise, the **FibreFlex PRO** has the same properties as the **FibreFlex** (look at p. 12).

CONSTRUCTION FIBREFLEX PRO

This drawing shows the **FibreFlex PRO** pipe type:



1. PE-Xa medium pipe
2. Temperature-resistant adhesive layer
3. High temperature aramid fibre mesh
4. Temperature-resistant adhesive layer
incl. Oxygen diffusion barrier
5. Medium pipe outer layer
6. Flexible polyurethan foam (PUR)
7. Casing

Data overview: **FibreFlex PRO** medium pipe

Material:	webbed polyethylene PE-X, strengthened with aramid fibres; basic material PE-Xa; DIN 16892
Cross-linking:	Peroxid (Engelverfahren) PE-Xa
Density:	938 – 940 kg/m ³
Tear strength:	20 °C: 26 – 30 N/mm ² ; 80 °C: 18 – 20 N/mm ²
Special heat expansion	0,175 mm/mK
Elasticity module	600 N/mm ²
Crystallite melting range:	130 – 136 °C
Surface roughness k:	0,007 mm
Properties:	Very good chemical resistance after DIN 8075
Bonding agent:	PE-modified, stabilised for heat and highly heat resistant
Oxygen diffusion barrier	Organic EVOH-yellow, stabilised for heat, < 0,10 g/m ³ d
Deployment area:	95 °C (constant temp.) 10/16 bar; t max. 115 °C (sliding)

Tab. 20: Properties **FibreFlex PRO** medium pipe

MEASUREMENTS

The RK Infra FibreFlex PRO is available as a UNO- or DUO-pipe.

The available pipe dimensions with corresponding measurements are listed on the following table.

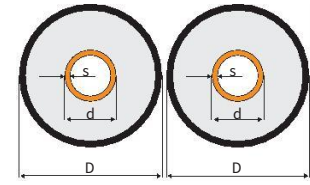

FibreFlex PRO UNO.

Typ	DN	Mediumrohr Ø [mm]	Außenmantel Ø [mm]	Min. Biegeradius [m]	Gewicht [kg]	Maxi-Coil [m]
32/76	25	32,0 x 2,9	76	0,70	1,1	570
32/91 Plus	25	32,0 x 2,9	91	0,90	1,3	570
32/111 Plus ²	25	32,0 x 2,9	111	0,90	1,9	410
40/91	32	40,0 x 3,7	91	0,90	1,9	570
40/111 Plus	32	40,0 x 3,7	111	0,90	1,9	570
40/126 Plus ²	32	40,0 x 3,7	126	1,00	2,1	410
50/111	40	47,6 x 3,6	111	0,90	2,0	570
50/126 Plus	40	47,6 x 3,6	126	1,00	2,2	410
63/126	50	58,5 x 4,0	126	1,00	2,4	300
63/142 Plus	50	58,5 x 4,0	142	1,10	2,7	410
75/142	65	69,5 x 4,6	142	1,10	2,9	300
75/162 Plus	65	69,5 x 4,6	162	1,20	3,5	300
90/162	80	84,0 x 6,0	162	1,20	4,0	225
90/182 Plus	80	84,0 x 6,0	182	1,30	4,7	225
110/162	100	101,0 x 6,5	162	1,20	4,3	150
110/182 Plus	100	101,0 x 6,5	182	1,30	5,0	150
110/202 Plus ²	100	101,0 x 6,5	202	1,30	5,4	86
125/182	100	116,0 x 6,8	182	1,30	5,1	150
125/202 Plus	100	116,0 x 6,8	202	1,40	6,0	86
125/225 Plus ²	100	116,0 x 6,8	225	1,60	7,1	80
140/202	125	127,0 x 7,1	202	1,40	6,3	86
140/225 Plus	125	127,0 x 7,1	225	1,60	7,5	80
160/225	150	144,0 x 7,5	225	1,60	7,7	150

Beware: When making calculations, make sure to consider that two DUO pipes are needed.

*Also available as FibreFlex PRO PN16 on customer request corresponding with delivery!

¹Up to 150m

Tab. 21: Measurements FibreFlex PRO UNO

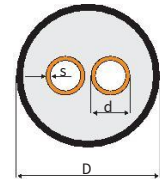

FibreFlex PRO DUO.

Typ	DN	Mediumrohr Ø [mm]	Außenmantel Ø [mm]	Min. Biegeradius [m]	Gewicht [kg]	Maxi-Coil [m]
32+32/111	25	32,0 x 2,9 / 32,0 x 2,9	111	0,90	1,9	410
32+32/126 Plus	25	32,0 x 2,9 / 32,0 x 2,9	126	0,90	2,3	300
32+32/142 Plus ²	25	32,0 x 2,9 / 32,0 x 2,9	142	1,00	2,7	225
40+40/126	32	40,0 x 3,7 / 40,0 x 3,7	126	0,90	2,6	300
40+40/142 Plus	32	40,0 x 3,7 / 40,0 x 3,7	142	1,00	2,9	225
40+40/162 Plus ²	32	40,0 x 3,7 / 40,0 x 3,7	162	1,20	3,5	150
50+50/162	40	47,6 x 3,6 / 47,6 x 3,6	162	1,20	3,6	150
50+50/182 Plus	40	47,6 x 3,6 / 47,6 x 3,6	182	1,30	4,3	86
63+63/182	50	58,5 x 4,0 / 58,5 x 4,0	182	1,30	4,5	86
63+63/202 Plus	50	58,5 x 4,0 / 58,5 x 4,0	202	1,40	5,3	80
75+75/202	65	69,5 x 4,6 / 69,5 x 4,6	202	1,40	5,7	80
75+75/225Plus	65	69,5 x 4,6 / 69,5 x 4,6	225	1,60	6,6	150*
90+90/225	80	84,0 x 6,0 / 84,0 x 6,0	225	1,60	7,3	150*

* Also available as FibreFlex PRO PN16 on customer request corresponding with delivery! Up to 150m of

¹Special ring bundle D 2,9 m / B 2,4 m

*With an outer jacket of 22t, the coil is wound to a width of 2,40m as standard. With all other dimensions, the standard width is 1,20m.

Tab. 22: Measurement FibreFlex PRO DUO

HEAT LOSS CALCULATIONS



HEAT LOSS CALCULATIONS

The heat loss of a FibreFlex PRO UNO or DUO pipe is calculated based on the following requirements:

Calculation basics	
Verlegeart FibreFlex PRO UNO:	2m Rohr erdverlegt pro Trassenmeter
Verlegeart FibreFlex PRO DUO:	1m Rohr erdverlegt pro Trassenmeter
Rohrabstand:	$a = 0,10\text{ m}$
Überdeckungshöhe:	$H = 0,80\text{ m}$
Erdreichtemperatur:	$T_E = 10\text{ °C}$
Leitfähigkeit des Bodens:	$\lambda_E = 1,0\text{ W/mK}$
Leitfähigkeit des PUR-Schaumes:	$\lambda_{PU} = 0,0210\text{ W/mK}$
Leitfähigkeit des PEX-Rohres:	$\lambda_{PEXa} = 0,38\text{ W/mK}$
Leitfähigkeit des PE-Mantels:	$\lambda_{PE} = 0,33\text{ W/mK}$

Heat loss in operation

$$Q = U \cdot [T_B - T_E] \text{ [W/m]}$$

$$U = \text{Wärmedurchgangskoeffizient [W/mK]}$$

$$T_B = \text{Mittlere Betriebstemperatur [°C]}$$

$$T_E = \text{Mittlere Erdreichtemperatur [°C]}$$

$$VL = \text{Vorlauf}$$

$$RL = \text{Rücklauf}$$

Tab. 23: heat loss calculations basics for FibreFlex PRO



Abb. 22: pipe trench UNO pipe



Abb. 23: Pipe trench DUO pipe

EXAMPLE FOR CALCULATING HEAT LOSS

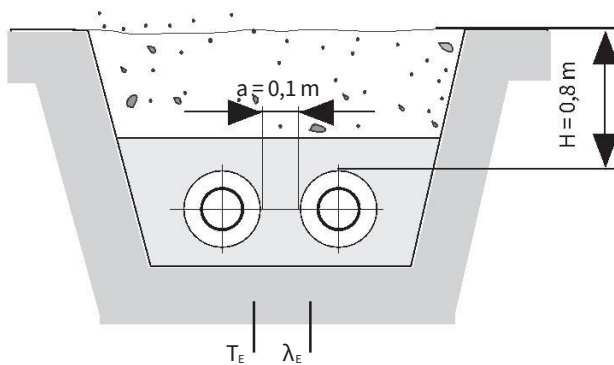
Flow temperature	80 °C
Return temperature	60 °C
Mid service temperature	70 °C
Heat loss from the table	10,36 W/m
Heat loss from a route meter	$10,36\text{ W/m} \cdot 2 = 20,72\text{ W/m}$

The value can be directly taken from the table for DUO cables.

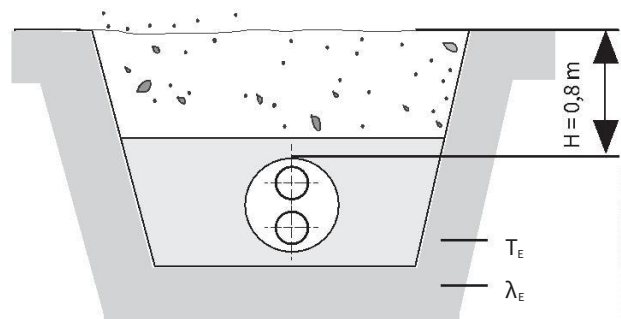
HEAT LOSS DATA

The calculation scheme results for heat loss of the FibreFlex PRO pipe UNO and DUO can be seen on the following tables:

FibreFlex PRO UNO

UNO PN10	U-Wert [W/mK]	Betriebstemperatur T [°C]		
		80°C	70°C	60°C
32/76	0,1431	20,04	17,18	14,31
32/91	0,1189	16,64	14,26	11,89
40/91	0,1487	20,82	17,85	14,87
40/111	0,1209	16,93	14,51	12,09
50/111	0,1442	20,19	17,31	14,42
50/126	0,1264	17,70	15,17	12,64
63/126	0,1577	22,08	18,93	15,77
63/142	0,1377	19,28	16,52	13,77
75/142	0,1680	23,51	20,12	16,80
75/162	0,1440	20,15	17,28	14,40
90/162	0,1813	25,38	21,76	18,13
90/182	0,1562	21,87	18,74	15,62
110/162	0,2432	34,05	29,19	24,32
110/182	0,2001	28,01	24,01	20,01
125/182	0,2536	35,50	30,43	25,36
125/202	0,2013	29,44	25,24	21,03
140/202	0,2460	34,44	29,52	24,60
140/225	0,2050	28,70	24,60	20,50
160/225	0,2550	35,70	30,60	25,50

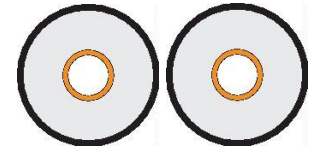

Note: in order to obtain the heat loss rate of a one meter pipe, the value (W/m) has to be multiplied by a factor of 2 for UNO pipes.

Tab. 24: Heat loss FibreFlexPRO UNO

FibreFlex PRO DUO

DUO PN10	U-Wert [W/mK]	Betriebstemperatur T [°C]		
		80°C	70°C	60°C
32+32/111	0,1936	13,55	11,61	9,68
32+32/126	0,1599	11,19	9,59	7,99
40+40/126	0,2203	15,41	13,22	11,01
40+40/142	0,1789	12,51	10,72	8,93
50+50/162	0,1866	13,06	11,20	9,33
50+50/182	0,1580	11,06	9,48	7,90
63+63/182	0,2116	14,81	12,70	10,58
63+63/202	0,1773	12,41	10,64	8,87
75+75/202	0,2353	16,47	14,12	11,76
75+75/225	0,1928	13,49	11,57	9,64
90+90/225	0,2781	19,47	16,69	13,91

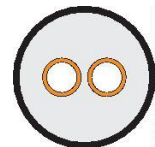

Tab. 25: Heat loss FibreFlexPRO DUO

TEMPERATURE, PRESSURE, SERVICE LIFE



TEMPERATURE UND PRESSURE LIMIT

The values in the table are dependent on the constant operating temperature and operating time of the **RK Infra FibreFlex PRO**.

The permissible operating pressures under the respective operating temperatures can be seen from the following table. These results are based on the safety factor according to ISO 15875-2.

Druckbegrenzung von FibreFlex Pro PN10 (10bar)

Betriebstemperatur	Sicherheitsfaktor	1 Jahr	5 Jahre	10 Jahre	20 Jahre	30 Jahre	50 Jahre
40°C	1,5	25,0	22,3	21,2	20,2	19,6	18,9
45°C	1,5	24,1	21,4	20,3	19,3	18,7	18
50°C	1,5	23,1	20,4	19,3	18,3	17,8	17,1
55°C	1,5	22,2	19,5	18,4	17,4	16,8	16,4
60°C	1,5	21,2	18,5	17,4	16,4	15,9	15,2
65°C	1,5	20,2	17,5	16,5	15,5	14,9	14,3
70°C	1,5	19,2	16,6	15,5	14,5	14	13,4
75°C	1,5	18,2	15,6	14,5	13,6	13,1	12,4
80°C	1,5	17,2	14,6	13,6	12,6	12,1	11,5
85°C	1,5	16,2	13,6	12,6	11,7	11,2	10,6
90°C	1,3	17,4	14,5	13,4	12,4	11,8	-
95°C	1,3	16,2	13,4	12,3	11,3	-	-
100°C	1,3	15,0	12,2	11,2	-	-	-
105°C	1,3	13,8	11,1	-	-	-	-
110°C	1,3	12,6	-	-	-	-	-
115°C	1,3	11,4	-	-	-	-	-
120°C	1,0	13,2	-	-	-	-	-

Tab. 26: Temperature and pressure limit **FibreFlex PRO PN 10**

Druckbegrenzung von FibreFlex Pro PN16 (16bar)

Betriebs-temperatur	Sicherheitsfaktor	1 Jahr	5 Jahre	10 Jahre	20 Jahre	30 Jahre	50 Jahre
40°C	1,5	40,0	35,6	33,9	32,3	21,4	30,3
45°C	1,5	38,5	34,2	32,5	30,8	29,9	28,8
50°C	1,5	37,0	32,7	31	29,3	28,4	27,3
55°C	1,5	35,5	31,1	29,6	27,8	26,9	25,8
60°C	1,5	33,9	29,6	28,1	26,3	25,4	24,3
65°C	1,5	32,4	28,1	26,5	24,8	23,9	22,9
70°C	1,5	30,8	26,5	24,9	23,3	22,4	21,4
75°C	1,5	29,2	24,9	23,3	21,7	20,9	19,9
80°C	1,5	27,5	23,3	21,7	20,2	19,4	18,4
85°C	1,5	25,9	21,7	20,2	18,7	17,9	16,9
90°C	1,3	27,9	23,2	21,4	19,8	18,9	-
95°C	1,3	26,0	21,4	19,6	18,1	-	-
100°C	1,3	24,0	19,6	18,8	-	-	-
105°C	1,3	22,1	17,8	-	-	-	-
110°C	1,3	20,1	-	-	-	-	-
115°C	1,3	18,2	-	-	-	-	-
120°C	1,0	21,1	-	-	-	-	-

Tab. 27: Temperature and pressure limit **FibreFlex PRO PN 16**

According to OFI ZG 200-2, the technical specification must meet the safety factor 1,5 for design temperatures, 1,3 for maximum service temperatures and 1 for incidents (+125°C):

The minimum requirements for long-term behaviour according to the specifications of DIN 16892 are met.

OPERATIONAL LIFETIME with the Miner’s rule for RK Infra FibreFlex PRO

Running heating networks are operated with different flow and return temperatures T_1 to T_n throughout the year. The resulting service life (D) of FibreFlex PRO pipes can be calculated according to Miner's rule ISO 13760.

SERVICE LIFE CALCULATIONS

$$D = \left(\frac{f_1/8760}{D_1} + \frac{f_2/8760}{D_2} + \dots + \frac{f_n/8760}{D_n} \right)^{-1}$$

- D Betriebsdauer in Jahren beim Betrieb mit wechselnden Temperaturen zwischen T_1 bis T_n
- D_1 bis D_n Betriebsdauer in Jahren beim Betrieb mit konstanter Temperatur T_1 bis T_n
- f_1 bis f_n Anteilige jährliche Betriebsstunden bei Betrieb mit Mediumtemperatur T_1 bis T_n

EXAMPLE FOR SERVICE LIFE CALCULATIONS

The basis is a typical temperature collective in heating networks over a year with flexible operation.

Main pipeline seasonally	80 °C - 95 °C
Return pipeline	50 °C - 55 °C
Operating pressure	9/15 bar
1 year	365 days = 8760 h

Temperature	Service hours	Service life (Druck PN 10/ PN16)
$T_1 = 60\text{ °C}$	$f_1 = 0\text{ h}$	$D_1 = 100\text{ years (14,9 bar/22,5 bar)}$
$T_2 = 65\text{ °C}$	$f_2 = 0\text{ h}$	$D_2 = 100\text{ years (14,0 bar/22,0 bar)}$
$T_3 = 70\text{ °C}$	$f_3 = 0\text{ h}$	$D_3 = 100\text{ years (13,2 bar/21,0 bar)}$
$T_4 = 75\text{ °C}$	$f_4 = 0\text{ h}$	$D_4 = 100\text{ years (12,1 bar/19,5 bar)}$
$T_5 = 80\text{ °C}$	$f_5 = 3868\text{ h}$	$D_5 = 75\text{ years (11,0 bar/18,0 bar)}$
$T_6 = 85\text{ °C}$	$f_6 = 3720\text{ h}$	$D_6 = 50\text{ years (10,6 bar/16,9 bar)}$
$T_7 = 90\text{ °C}$	$f_7 = 1004\text{ h}$	$D_7 = 30\text{ years (10,3 bar/16,4 bar)}$
$T_8 = 95\text{ °C}$	$f_8 = 168\text{ h}$	$D_8 = 20\text{ years (9,8 bar/15,7 bar)}$

Service life (D) is calculated according to ISO 13760 based on the values from OFI ZG 200-2: 52.2 years.

TECHNICAL DESCRIPTION



MEDIUM PIPE PN 6

The pre-insulated and flexible pipe system with a medium pipe is made from and strengthened by cross-linked fibres of polyethylene (PE-Xa) as well as a PUR heat isolation is perfect for deployment in district heating networks with temperatures reaching up to 95°C and an operating pressure up to 6 bar. The pipe system is created for ground laying. The medium pipe consists of cross-linked polyethylene PE-Xa (DIN16892). With this standard plastic piping system, the pipe can be transported at a constant temperature of 80°C and an operating pressure of 6 bar.

The PE-Xa medium pipe is easy to process despite its higher chemical and corrosion resistance. At the same time, it is free from harmful substances which also makes it environmentally friendly. To prevent the oxygen from entering the system, an organic oxygen diffusion barrier (EVOH DIN 4726) is put on the medium pipe.

CONSTRUCTION HEATFLEX

This drawing shows the construction of the HeatFlex pipe:

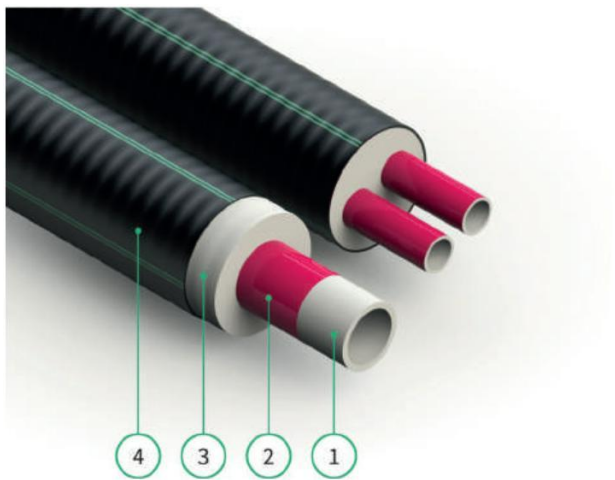

1. PE-Xa medium pipe
2. oxygen diffusion barrier
3. flexible polyurethane foam (PUR)
4. Casing

Data overview: HeatFlex medium pipe

Material:	Cross-linked Polyethylene PE-X, basic material PE-HD, DIN 16892/16893
Cross-linking:	Peroxide (Engelverfahren) PE-Xa
Density:	938 – 940 kg/m ³
Tear strength:	20 °C: 26 – 30 N/mm ² , 80 °C: 18 – 20 N/mm ²
Special heat expansion	0,175 mm/mK
Elasticity module	600 N/mm ²
Crystallite melting range:	130 – 136 °C
Surface roughness k:	0,007 mm
Qualities:	Very good chemical resistance after DIN 8075
Bonding agent:	PE-modified, stabilised for heat
Oxygen diffusion barrier	Organic EVOH-barrier red stabilised for heat, < 0,10 g/m ³ d
Deployment area:	80 °C (constant temp.) 6 bar, t max. 95 °C (sliding)

Tab. 28: properties HeatFlex medium pipe

MEASUREMENTS

The **RK Infra HeatFlex** is available as a UNO- or DUO-pipe.
The available pipe dimensions with corresponding measurements are listed on the following table.

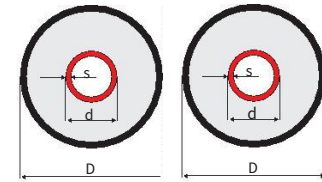

HeatFlex UNO

Type	DN	inches ["]	Inside pipe PEX d x s [mm]	outer jacket D max. [mm]	Min. Bending radius [m]	Volume Inside pipe [l/m]	weight [kg/m]	max. Delivery length Maxi-Ring [m]
25/76	20	3/4	25 x 2,3	79	0,7	0,32	0,90	770
25/91 PLUS	20	3/4	25 x 2,3	94	0,9	0,32	1,22	550
25/111 PLUS ²	20	3/4	25 x 2,3	114	0,9	0,32	1,68	410
32/76	25	1	32 x 2,9	79	0,7	0,53	1,00	770
32/91 PLUS	25	1	32 x 2,9	94	0,9	0,53	1,30	550
32/111 PLUS ²	25	1	32 x 2,9	114	0,9	0,53	1,76	410
40/91	32	1 1/4	40 x 3,7	94	0,9	0,83	1,39	550
40/111 PLUS	32	1 1/4	40 x 3,7	114	0,9	0,83	1,80	410
40/126 PLUS ²	32	1 1/4	40 x 3,7	129	1,0	0,83	2,17	300
50/111	40	1 1/2	50 x 4,6	114	0,9	1,30	1,97	410
50/126 PLUS	40	1 1/2	50 x 4,6	129	1,0	1,30	2,32	300
63/126	50	2	63 x 5,8	129	1,0	2,07	2,60	300
63/142 PLUS	50	2	63 x 5,8	145	1,1	2,07	3,00	225
75/142	65	2 1/2	75 x 6,8	145	1,1	2,96	3,39	225
75/162 PLUS	65	2 1/2	75 x 6,8	165	1,2	2,96	3,85	149
90/162	80	3	90 x 8,2	165	1,2	4,25	4,56	149
90/182 PLUS	80	3	90 x 8,2	185	1,3	4,25	4,90	86
110/162	100	4	110 x 10,0	165	1,2	6,36	5,10	149
110/182 PLUS	100	4	110 x 10,0	185	1,3	6,36	5,69	86
110/202 PLUS ²	100	4	110 x 10,0	205	1,4	6,36	6,94	80
125/182	125	5	125 x 11,4	185	1,3	8,20	6,37	86
125/202 PLUS	125	5	125 x 11,4	205	1,4	8,20	6,93	80
140/202	125	5	140 x 12,7	205	1,4	10,31	7,60	80
160/250	150	6	160 x 14,6	250	-	13,43	11,31	12

Note: when calculating, bear in mind that you need two UNO pipes.

Tab. 29: Measurements HeatFlex UNO

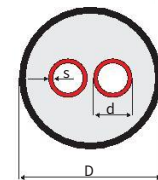

HeatFlex DUO

Type	DN	inches ["]	Inside pipe PEX d x s [mm]	outer jacket D max. [mm]	Minimum Bending radius [m]	Volume Inside pipe [l/m]	weight [kg/m]	max. Delivery length Maxi-Ring [m]
25+25/91	20 + 20	2 x 3/4	2 x 25 x 2,3	94	0,9	2 x 0,32	1,34	550
25+25/111 PLUS	20 + 20	2 x 3/4	2 x 25 x 2,3	114	0,9	2 x 0,32	1,73	410
32+32/111	25 + 25	2 x 1	2 x 32 x 2,9	114	0,9	2 x 0,53	1,87	410
32+32/126 PLUS	25 + 25	2 x 1	2 x 32 x 2,9	129	1,0	2 x 0,53	2,23	300
40+40/126	32 + 32	2 x 1 1/4	2 x 40 x 3,7	129	1,0	2 x 0,83	2,48	300
40+40/142 PLUS	32 + 32	2 x 1 1/4	2 x 40 x 3,7	145	1,1	2 x 0,83	2,85	225
50+50/162	40 + 40	2 x 1 1/2	2 x 50 x 4,6	165	1,2	2 x 1,30	3,96	149
50+50/182 PLUS	40 + 40	2 x 1 1/2	2 x 50 x 4,6	185	1,3	2 x 1,30	4,31	86
63+63/182	50 + 50	2 x 2	2 x 63 x 5,8	185	1,3	2 x 2,07	5,28	86
63+63/202 PLUS	50 + 50	2 x 2	2 x 63 x 5,8	205	1,4	2 x 2,07	5,44	80
75+75/202	65 + 65	2 x 2 1/2	2 x 75 x 6,8	205	1,4	2 x 2,96	6,27	80

Tab. 30: Measurements HeatFlex DUO

HEAT LOSS CALCULATIONS



HEAT LOSS CALCULATIONS

The calculation scheme results for heat loss of the HeatFlex pipe UNO and DUO can be seen on the following tables:

Calculation basics		Heat loss in operation	
Verlegeart HeatFlex UNO:	2 m Rohr erdverlegt pro Trassenmeter	$Q = U \cdot [T_B - T_E]$ [W/m]	
Verlegeart HeatFlex DUO:	1 m Rohr erdverlegt pro Trassenmeter	$U =$ Wärmedurchgangskoeffizient [W/mK]	
Rohrabstand:	$a = 0,10$ m	$T_B =$ Mittlere Betriebstemperatur [°C]	
Überdeckungshöhe:	$H = 0,80$ m	$T_E =$ Mittlere Erdreichtemperatur [°C]	
Erdreichtemperatur:	$T_E = 10$ °C	$VL =$ Vorlauf	
Leitfähigkeit des Bodens:	$\lambda_E = 1,0$ W/mK	$RL =$ Rücklauf	
Leitfähigkeit des PUR-Schaumes:	$\lambda_{PU} = 0,0210$ W/mK		
Leitfähigkeit des PEX-Rohres:	$\lambda_{PEa} = 0,38$ W/mK		
Leitfähigkeit des PE-Mantels:	$\lambda_{PE} = 0,33$ W/mK		

Tab. 31: Heat loss calculations for HeatFlex



Abb. 24: pipe trench UNO-Rohr



Abb. 25: pipe trench DUO-Rohr

EXAMPLE FOR CALCULATING HEAT LOSS HeatFlex 75/142

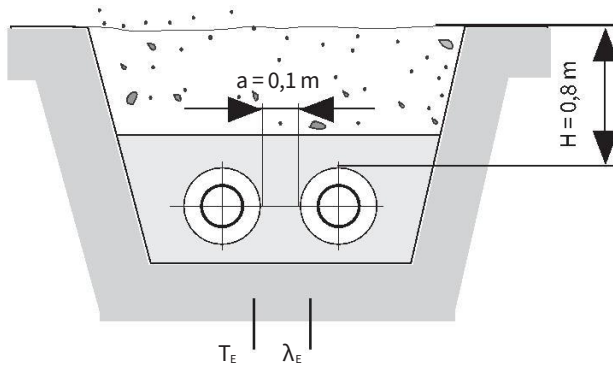
Flow temperature	80 °C
Return temperature	60 °C
Mid operation temperature	70 °C
Heat loss from the table	11,42 W/m
Heat loss from one route meter	$11,42 \text{ W/m} \cdot 2 = 22,84 \text{ W/m}$

The value can be directly taken from the table for DUO pipes.

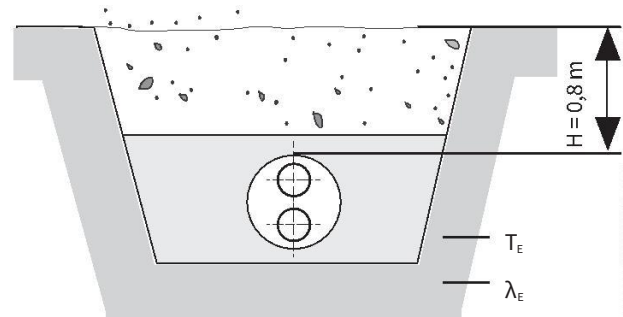
HEAT LOSS DATA

HeatFlex

The calculation scheme results for heat loss of the HeatFlex UNO and DUO pipes can be seen on the following tables:

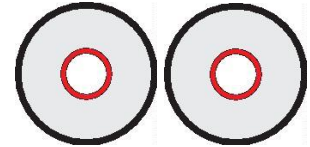

HeatFlex UNO

Wärmeverluste Q [W/m] für ein Einfachrohr pro Rohrmeter

UNO PN 6	U-Value [W/mK]	mittlere Betriebstemperatur t_B [°C]			
		40 °C	50 °C	60 °C	70 °C
25/76	0,114	3,43	4,57	5,71	6,85
25/91 PLUS	0,099	2,97	3,96	4,95	5,94
25/111 PLUS ²	0,087	2,59	3,45	4,32	5,18
32/76	0,144	4,33	5,77	7,21	8,65
32/91 PLUS	0,121	3,63	4,83	6,04	7,25
32/111 PLUS ²	0,103	3,07	4,10	5,12	6,15
40/91	0,151	4,53	6,03	7,54	9,05
40/111 PLUS	0,123	3,70	4,93	6,16	7,40
40/126 PLUS ²	0,111	3,32	4,43	5,54	6,64
50/111	0,155	4,64	6,19	7,74	9,29
50/126 PLUS	0,136	4,07	5,42	6,77	8,13
63/126	0,176	5,29	7,05	8,81	10,57
63/142 PLUS	0,153	4,59	6,12	7,64	9,17
75/142	0,191	5,71	7,61	9,52	11,42
75/162 PLUS	0,161	4,82	6,43	8,03	9,64
90/162	0,205	6,15	8,20	10,25	12,31
90/182 PLUS	0,174	5,22	6,96	8,70	10,44
110/162	0,295	8,85	11,80	14,75	17,69
110/182 PLUS	0,235	7,04	9,39	11,74	14,08
110/202 PLUS ²	0,199	5,97	7,96	9,94	11,93
125/182	0,302	9,05	12,06	15,08	18,10
125/202 PLUS	0,245	7,35	9,80	12,25	14,70
140/202	0,308	9,24	12,33	15,41	18,49

Note: in order to obtain the heat loss rate of a one-meter pipe, the value (W/m) has to be multiplied by a factor of 2 for UNO pipes.

Tab. 32: Heat loss HeatFlex UNO

HeatFlex DUO

Heat loss Q [W/m] für ein Doppelrohr pro Trassenmeter

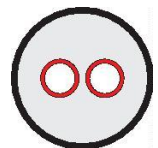

DUO PN 6	U-Value [W/mK]	mittlere Betriebstemperatur t_B [°C]			
		40 °C	50 °C	60 °C	70 °C
25+25/91	0,180	5,39	7,18	8,98	10,77
25+25/111 PLUS	0,139	4,17	5,56	6,95	8,34
32+32/111	0,184	5,51	7,35	9,18	11,02
32+32/126 PLUS	0,156	4,68	6,24	7,80	9,36
40+40/126	0,210	6,31	8,42	10,52	12,62
40+40/142 PLUS	0,174	5,21	6,95	8,68	10,42
50+50/162	0,196	5,87	7,83	9,79	11,74
50+50/182 PLUS	0,167	5,00	6,67	8,34	10,01
63+63/182	0,238	7,15	9,54	11,92	14,31
63+63/202 PLUS	0,196	5,89	7,85	9,81	11,77
75+75/202	0,273	8,19	10,92	13,65	16,37

Tab. 33: Heat loss HeatFlex DUO

TEMPERATURE, PRESSURE, SERVICE LIFE



TEMPERATURE AND PRESSURE LIMIT

The values in the table are dependent on the constant operating temperature and operating time of the **RK Infra HeatFlex**.

The permissible operating pressures under the respective operating temperatures can be seen from the following table. These results are based on the safety factor according to ISO 15875-2.

Pressure limit at service life for PN6

Service-temperature	Safety factor	1 year	10 years	15 years	20 years	25 years	30 years	50 years	100 years
40 °C	1,5	10,5 bar	10,2 bar	10,2 bar	10,1 bar	10,1 bar	10,1 bar	10,0 bar	9,8 bar
50 °C	1,5	9,3 bar	9,1 bar	9,0 bar	9,0 bar	9,0 bar	9,0 bar	8,9 bar	8,7 bar
60 °C	1,5	8,4 bar	8,1 bar	8,1 bar	8,0 bar	8,0 bar	8,0 bar	8,0 bar	7,8 bar
65 °C	1,5	7,9 bar	7,7 bar	7,6 bar	7,6 bar	7,6 bar	7,6 bar	7,5 bar	7,3 bar
70 °C	1,5	7,5 bar	7,3 bar	7,2 bar	7,2 bar	7,2 bar	7,2 bar	7,1 bar	
75 °C	1,5	7,1 bar	6,9 bar	6,8 bar	6,8 bar	6,8 bar	6,8 bar	6,7 bar	
80 °C	1,5	6,7 bar	6,5 bar	6,5 bar	6,5 bar	6,4 bar	6,3 bar		
85 °C	1,3	6,9 bar	6,7 bar	6,6 bar	6,9 bar				
90 °C	1,3	7,0 bar	6,1 bar						
95 °C	1,0	8,6 bar	6,0 bar						

Tab. 34: Temperature and pressure limit HeatFlex after ISO 15875-2

The minimum requirements for long-term behaviour according to the specifications of DIN 16892/16893 are met. In addition, there is still the possibility of using the pressure limitation table according to DIN 16893 with a safety factor of 1.25.

Betriebs-temperatur	Sicherheitsfaktor	1 Jahr	10 Jahre	15 Jahre	25 Jahre	50 Jahre
40°C	1,25	12,5 bar	12,1 bar	12,0 bar	12,0 bar	11,9 bar
50°C	1,25	11,1 bar	10,8 bar	10,8 bar	10,7 bar	10,6 bar
60°C	1,25	9,9 bar	9,7 bar	9,6 bar	9,5 bar	9,5 bar
70°C	1,25	8,9 bar	8,6 bar	8,5 bar	8,5 bar	8,5 bar
80°C	1,25	8,0 bar	7,7 bar	7,6 bar	7,6 bar	-
90°C	1,25	7,2 bar	6,9 bar	6,9 bar	-	-
95°C	1,25	6,8 bar	6,6 bar	-	-	-

Tab. 34a: Temperature and pressure limit PE-Xa according to DIN 16892/93

SERVICE LIFE WITH THE MINER'S RULE HeatFlex

Running heating networks are operated with different flow and return temperatures T_1 to T_n throughout the year. The resulting service life (D) of HeatFlex pipes can be calculated according to Miner's rule ISO 13760.

SERVICE LIFE CALCULATION

$$D = \left(\frac{f_1/8760}{D_1} + \frac{f_2/8760}{D_2} + \dots + \frac{f_n/8760}{D_n} \right)^{-1}$$

- D Betriebsdauer in Jahren beim Betrieb mit wechselnden Temperaturen zwischen T_1 bis T_n
- D_1 bis D_n Betriebsdauer in Jahren beim Betrieb mit konstanter Temperatur T_1 bis T_n
- f_1 bis f_n Anteilige jährliche Betriebsstunden bei Betrieb mit Mediumtemperatur T_1 bis T_n

EXAMPLE FOR SERVICE LIFE CALCULATIONS

The basis is a typical temperature collective in heating networks over a year of flexible operation:

Main pipeline yearly flow	70 °C - 90 °C
Return flow	50 °C - 55 °C
Service pressure	6 bar
1 year	365 days = 8760 h

Temperature	Service hours	Service life (pressure)
$T_1 = 60$ °C	$f_1 = 0$ h	$D_1 = 100$ years (7,8 bar)
$T_2 = 65$ °C	$f_2 = 0$ h	$D_2 = 100$ years (7,3 bar)
$T_3 = 70$ °C	$f_3 = 3528$ h	$D_3 = 95$ years (6,9 bar)
$T_4 = 75$ °C	$f_4 = 840$ h	$D_4 = 55$ years (6,6 bar)
$T_5 = 80$ °C	$f_5 = 3720$ h	$D_5 = 32$ years (6,3 bar)
$T_6 = 85$ °C	$f_6 = 504$ h	$D_6 = 19$ years (6,9 bar)
$T_7 = 90$ °C	$f_7 = 168$ h	$D_7 = 11$ years (6,3 bar)
$T_8 = 95$ °C	$f_8 = 0$ h	$D_8 = 10$ years (6,0 bar)

Calculated service life (D) according to ISO 13760 on the basis values after ISO 15875-2: 41, 6 years

PRESSURE LOSS AT 20 K

FibreFlex & FibreFlex PRO

PRESSURE LOSS MEDIUM PIPE FIBREFLEX AT VL 80 °C AND RL 60 °C

TYP:		25		32		40		50		63			
Volume	electricity	Performance at spread 20 K		25x2,2		32x2,5		40x2,8		47,6x3,6		58,5x4,0	
[l/s]	[m ³ /h]	[kW]	v	R	v	R	v	R	v	R	v	R	
			[m/s]	[Pa/m]	[m/s]	[Pa/m]	[m/s]	[Pa/m]	[m/s]	[Pa/m]	[m/s]	[Pa/m]	
0,06	0,2	4,9	0,18	23,8									
0,07	0,3	5,7	0,21	31,2									
0,08	0,3	6,5	0,24	39,5									
0,09	0,3	7,4	0,27	48,6									
0,10	0,4	8,2	0,30	58,6									
0,11	0,4	9,0	0,33	69,3									
0,12	0,4	9,8	0,36	80,9									
0,13	0,5	10,6	0,39	93,3	0,23	25,5							
0,14	0,5	11,5	0,42	106,5	0,24	29,1							
0,15	0,5	12,3	0,45	120,4	0,26	32,8							
0,16	0,6	13,1	0,48	135,2	0,28	36,8							
0,18	0,6	14,7	0,54	166,9	0,31	45,4							
0,20	0,7	16,4	0,60	201,7	0,35	54,7							
0,22	0,8	18,0	0,66	239,5	0,38	64,9							
0,24	0,9	19,6	0,72	280,3	0,42	75,8							
0,26	0,9	21,3	0,78	323,9	0,45	87,5	0,28	27,3					
0,28	1,0	22,9	0,84	370,5	0,49	99,9	0,30	31,1					
0,30	1,1	24,5	0,90	420,0	0,52	113,1	0,32	35,2					
0,35	1,3	28,6	1,05	556,2	0,61	149,3	0,38	46,3					
0,40	1,4	32,7	1,20	710,1	0,70	190,0	0,43	58,9					
0,45	1,6	36,8	1,35	881,5	0,79	235,3	0,48	72,8	0,35	33,5			
0,50	1,8	40,9			0,87	285,0	0,54	88,0	0,39	40,5			
0,55	2,0	45,0			0,96	339,0	0,59	104,5	0,43	48,0			
0,60	2,2	49,1			1,05	397,5	0,65	122,3	0,47	56,2			
0,70	2,5	57,3			1,22	527,3	0,75	161,8	0,55	74,2			
0,80	2,9	65,5			1,40	674,1	0,86	206,3	0,62	94,5			
0,90	3,2	73,6					0,97	255,8	0,70	117,0	0,45	39,7	
1,00	3,6	81,8					1,08	310,3	0,78	141,7	0,50	48,0	
1,10	4,0	90,0					1,18	369,6	0,86	168,6	0,55	57,1	
1,20	4,3	98,2					1,29	433,8	0,94	197,7	0,60	66,8	
1,30	4,7	106,4							1,01	228,9	0,65	77,3	
1,40	5,0	114,6							1,09	262,2	0,70	88,4	
1,50	5,4	122,7							1,17	297,7	0,75	100,3	
1,60	5,8	130,9							1,25	335,3	0,80	112,8	
1,70	6,1	139,1							1,33	374,9	0,85	126,0	
1,80	6,5	147,3							1,40	416,7	0,90	139,9	
1,90	6,8	155,5							1,48	460,5	0,95	154,5	
2,00	7,2	163,7									1,00	169,7	
2,20	7,9	180,0									1,10	202,2	
2,40	8,6	196,4									1,20	237,3	
2,60	9,4	212,8									1,30	275,1	
2,80	10,1	229,1									1,40	315,5	
3,00	10,8	245,5									1,50	358,5	

Tab. 35: Pressure loss at 20 K FibreFlex measurements 25–63

Material values water for
 Pressure loss calculations R [Pa/m]
 - spec. Heat capacity: 4185 J/(kgK)
 - middle spec. density: 977,66 kg/m³
 - middle kin. viscosity: 3,29357 * 10⁻⁷ m²/s

recommended flow rate v [m/s]
 - House connection between 0,4-0,8 m/s
 reduced flow rate to avoid noise in residential buildings
 - Main continuous load 1,5 m/s
 - Main short load 2,0 m/s

PRESSURE LOSS MEDIUM PIPE FIBREFLEX AT VL 80 °C AND RL 60 °C

TYP:		75		90		110		125		140		160		
Volume electricity [l/s]	[m ³ /h]	Performance at spread 20 K [kW]	69,5x4,6		84x6,0		101x6,5		116x6,8		127x7,1		144x7,5	
			v [m/s]	R [Pa/m]	v [m/s]	R [Pa/m]	v [m/s]	R [Pa/m]	v [m/s]	R [Pa/m]	v [m/s]	R [Pa/m]	v [m/s]	R [Pa/m]
2,40	8,6	196,4	0,84	99,8	0,59	42,2								
2,60	9,4	212,8	0,91	115,6	0,64	48,8								
2,80	10,1	229,1	0,98	132,4	0,69	55,8								
3,00	10,8	245,5	1,05	150,3	0,74	63,3								
3,30	11,9	270,0	1,16	179,2	0,81	75,4								
3,50	12,6	286,4	1,23	199,7	0,86	84,0								
3,80	13,7	311,0	1,33	232,5	0,93	97,7								
4,00	14,4	327,3	1,40	255,7	0,98	107,3								
4,30	15,5	351,9	1,51	292,3	1,06	122,6	0,71	46,1						
4,50	16,2	368,2	1,58	318,1	1,11	133,3	0,74	50,1						
4,80	17,3	392,8	1,68	358,6	1,18	150,2	0,79	56,4						
5,00	18,0	409,1	1,75	386,9	1,23	161,9	0,82	60,8						
5,30	19,1	433,7	1,86	431,3	1,30	180,4	0,87	67,6						
5,50	19,8	450,1	1,93	462,2	1,35	193,2	0,90	72,4						
5,80	20,9	474,6	2,03	510,4	1,42	213,1	0,95	79,8						
6,00	21,6	491,0	2,10	543,8	1,47	227,0	0,99	85,0						
6,30	22,7	515,5	2,21	595,8	1,55	248,5	1,04	92,9						
6,50	23,4	531,9	2,28	631,8	1,60	263,4	1,07	98,5						
7,00	25,2	572,8			1,72	302,3	1,15	112,9	0,85	53,9				
7,50	27,0	613,7			1,84	343,8	1,23	128,3	0,91	61,1				
8,00	28,8	654,6			1,96	387,9	1,32	144,5	0,97	68,9				
8,50	30,6	695,6			2,09	434,5	1,40	161,7	1,03	77,0				
9,00	32,4	736,5			2,21	483,6	1,48	179,8	1,09	85,6				
9,50	34,2	777,4			2,33	535,2	1,56	198,9	1,15	94,6				
10,00	36,0	818,3					1,64	218,8	1,21	104,0	1,00	64,8		
10,50	37,8	859,2					1,73	239,6	1,27	113,8	1,05	70,9		
11,00	39,6	900,1					1,81	261,4	1,34	124,1	1,10	77,2		
11,50	41,4	941,0					1,89	284,0	1,40	134,7	1,15	83,9		
12,00	43,2	982,0					1,97	307,5	1,46	145,8	1,20	90,7		
12,50	45,0	1022,9					2,06	331,9	1,52	157,3	1,25	97,9		
13,00	46,8	1063,8					2,14	357,2	1,58	169,2	1,30	105,2		
13,50	48,6	1104,7					2,22	383,4	1,64	181,6	1,35	112,9		
14,00	50,4	1145,6					2,30	410,5	1,70	194,3	1,40	120,8	1,07	62,6
14,50	52,2	1186,5							1,76	207,5	1,45	128,9	1,11	66,8
15,00	54,0	1227,4							1,82	221,0	1,50	137,3	1,15	71,1
16,00	57,6	1309,3							1,94	249,4	1,60	154,8	1,22	80,1
17,00	61,2	1391,1							2,06	279,3	1,70	173,4	1,30	89,7
18,00	64,8	1472,9							2,19	311,0	1,80	192,9	1,38	99,7
19,00	68,4	1554,8									1,90	213,4	1,45	110,3
20,00	72,0	1636,6									2,00	234,9	1,53	121,3
21,00	75,6	1718,4									2,10	257,5	1,61	132,9
22,00	79,2	1800,3									2,20	280,9	1,68	144,9
23,00	82,8	1882,1									2,30	305,4	1,76	157,5
24,00	86,4	1963,9											1,84	170,5
25,00	90,0	2045,7											1,91	184,0
26,00	93,6	2127,6											1,99	198,1
27,00	97,2	2209,4											2,07	212,6

Tab. 36: Pressure loss at 20 K FibreFlex measurement 75-160

PRESSURE LOSS AT 30 K

FibreFlex & FibreFlex PRO

PRESSURE LOSS MEDIUM PIPE FIBREFLEX AT VL 80 °C AND RL 50 °C

TYP:			25		32		40		50		63	
Volume electricity [l/s]	[m³/h]	Performance at spread 30 K [kW]	25x2,2		32x2,5		40x2,8		47,6x3,6		58,5x4,0	
			v	R	v	R	v	R	v	R	v	R
			[m/s]	[Pa/m]	[m/s]	[Pa/m]	[m/s]	[Pa/m]	[m/s]	[Pa/m]	[m/s]	[Pa/m]
0,06	0,2	7,4	0,18	24,7								
0,07	0,3	8,6	0,21	32,3								
0,08	0,3	9,8	0,24	40,9								
0,09	0,3	11,1	0,27	50,3								
0,10	0,4	12,3	0,30	60,5								
0,11	0,4	13,5	0,33	71,6								
0,12	0,4	14,8	0,36	83,6								
0,13	0,5	16,0	0,39	96,3	0,23	26,4						
0,14	0,5	17,2	0,42	109,9	0,24	30,0						
0,15	0,5	18,5	0,45	124,2	0,26	33,9						
0,16	0,6	19,7	0,48	139,4	0,28	38,0						
0,18	0,6	22,2	0,54	172,0	0,31	46,8						
0,20	0,7	24,6	0,60	207,7	0,35	56,5						
0,22	0,8	27,1	0,66	246,5	0,38	66,9						
0,24	0,9	29,5	0,72	288,3	0,42	78,1						
0,26	0,9	32,0	0,78	333,1	0,45	90,1	0,28	28,2				
0,28	1,0	34,5	0,84	380,9	0,49	102,9	0,30	32,1				
0,30	1,1	36,9	0,90	431,5	0,52	116,5	0,32	36,3				
0,35	1,3	43,1	1,05	570,9	0,61	153,6	0,38	47,8				
0,40	1,4	49,2	1,20	728,3	0,70	195,4	0,43	60,7				
0,45	1,6	55,4	1,35	903,4	0,79	241,8	0,48	74,9	0,35	34,5		
0,50	1,8	61,6			0,87	292,7	0,54	90,5	0,39	41,7		
0,55	2,0	67,7			0,96	348,0	0,59	107,5	0,43	49,5		
0,60	2,2	73,9			1,05	407,8	0,65	125,8	0,47	57,8		
0,70	2,5	86,2			1,22	540,4	0,75	166,2	0,55	76,3		
0,80	2,9	98,5			1,40	690,4	0,86	211,8	0,62	97,1		
0,90	3,2	110,8					0,97	262,5	0,70	120,2	0,45	40,9
1,00	3,6	123,1					1,08	318,1	0,78	145,5	0,50	49,4
1,10	4,0	135,4					1,18	378,8	0,86	173,1	0,55	58,7
1,20	4,3	147,7					1,29	444,3	0,94	202,8	0,60	68,7
1,30	4,7	160,0							1,01	234,7	0,65	79,4
1,40	5,0	172,3							1,09	268,8	0,70	90,8
1,50	5,4	184,7							1,17	305,0	0,75	102,9
1,60	5,8	197,0							1,25	343,4	0,80	115,8
1,70	6,1	209,3							1,33	383,8	0,85	129,3
1,80	6,5	221,6							1,40	426,4	0,90	143,5
1,90	6,8	233,9							1,48	471,1	0,95	158,4
2,00	7,2	246,2									1,00	174,0
2,20	7,9	270,8									1,10	207,1
2,40	8,6	295,4									1,20	243,0
2,60	9,4	320,1									1,30	281,6
2,80	10,1	344,7									1,40	322,8
3,00	10,8	369,3									1,50	366,6

Tab. 37: Pressure loss at 30 K FibreFlex measurement 25-63

Material values water for
 Pressure loss calculations R [Pa/m]
 - spec. Heat capacity: 4185 J/(kgK)
 - middle spec. density: 980,49 kg/m³
 middle kin. viscosity: 3,53238 * 10⁻⁷ m²/s

recommended flow rate v [m/s]
 House connection between 0,4-0,8 m/s
 reduced flow rate to avoid noise in residential buildings
 - Main continuous load 1,5 m/s
 - Main short load 2,0 m/s

PRESSURE LOSS MEDIUM PIPE FIBREFLEX AT VL 80 °C AND RL 50 °C

TYP:		75		90		110		125		140		160		
Volume electricity [l/s]	[m ³ /h]	Performance at spread 30 K [kW]	69,5x4,6 v [m/s]	R [Pa/m]	84x6,0 v [m/s]	R [Pa/m]	101x6,5 v [m/s]	R [Pa/m]	116x6,8 v [m/s]	R [Pa/m]	127x7,1 v [m/s]	R [Pa/m]	144x7,5 v [m/s]	R [Pa/m]
2,40	8,6	295,4	0,84	102,4	0,59	43,3								
2,60	9,4	320,1	0,91	118,5	0,64	50,1								
2,80	10,1	344,7	0,98	135,7	0,69	57,3								
3,00	10,8	369,3	1,05	154,0	0,74	65,0								
3,30	11,9	406,2	1,16	183,5	0,81	77,3								
3,50	12,6	430,9	1,23	204,4	0,86	86,1								
3,80	13,7	467,8	1,33	237,9	0,93	100,1								
4,00	14,4	492,4	1,40	261,5	0,98	109,9								
4,30	15,5	529,3	1,51	298,9	1,06	125,5	0,71	47,3						
4,50	16,2	554,0	1,58	325,1	1,11	136,5	0,74	51,4						
4,80	17,3	590,9	1,68	366,4	1,18	153,7	0,79	57,8						
5,00	18,0	615,5	1,75	395,3	1,23	165,7	0,82	62,3						
5,30	19,1	652,4	1,86	440,5	1,30	184,5	0,87	69,3						
5,50	19,8	677,1	1,93	471,9	1,35	197,6	0,90	74,2						
5,80	20,9	714,0	2,03	521,0	1,42	217,9	0,95	81,8						
6,00	21,6	738,6	2,10	555,0	1,47	232,0	0,99	87,0						
6,30	22,7	775,5	2,21	607,9	1,55	254,0	1,04	95,2						
6,50	23,4	800,2	2,28	644,4	1,60	269,1	1,07	100,8						
7,00	25,2	861,7			1,72	308,8	1,15	115,5	0,85	55,2				
7,50	27,0	923,3			1,84	351,1	1,23	131,2	0,91	62,6				
8,00	28,8	984,8			1,96	395,9	1,32	147,8	0,97	70,5				
8,50	30,6	1046,4			2,09	443,3	1,40	165,3	1,03	78,8				
9,00	32,4	1107,9			2,21	493,2	1,48	183,8	1,09	87,6				
9,50	34,2	1169,5			2,33	545,7	1,56	203,2	1,15	96,7				
10,00	36,0	1231,0					1,64	223,5	1,21	106,3	1,00	66,3		
10,50	37,8	1292,6					1,73	244,7	1,27	116,4	1,05	72,5		
11,00	39,6	1354,1					1,81	266,8	1,34	126,8	1,10	79,0		
11,50	41,4	1415,7					1,89	289,8	1,40	137,7	1,15	85,8		
12,00	43,2	1477,2					1,97	313,8	1,46	149,0	1,20	92,8		
12,50	45,0	1538,8					2,06	338,6	1,52	160,7	1,25	100,1		
13,00	46,8	1600,3					2,14	364,4	1,58	172,9	1,30	107,6		
13,50	48,6	1661,9					2,22	391,0	1,64	185,4	1,35	115,4		
14,00	50,4	1723,4					2,30	418,6	1,70	198,4	1,40	123,4	1,07	64,0
14,50	52,2	1785,0							1,76	211,8	1,45	131,7	1,11	68,3
15,00	54,0	1846,5							1,82	225,6	1,50	140,3	1,15	72,7
16,00	57,6	1969,6							1,94	254,4	1,60	158,1	1,22	81,9
17,00	61,2	2092,7							2,06	284,9	1,70	177,0	1,30	91,7
18,00	64,8	2215,8							2,19	317,1	1,80	196,9	1,38	101,9
19,00	68,4	2338,9									1,90	217,8	1,45	112,6
20,00	72,0	2462,0									2,00	239,7	1,53	123,9
21,00	75,6	2585,1									2,10	262,5	1,61	135,7
22,00	79,2	2708,2									2,20	286,4	1,68	147,9
23,00	82,8	2831,3									2,30	311,3	1,76	160,7
24,00	86,4	2954,4											1,84	174,0
25,00	90,0	3077,5											1,91	187,7
26,00	93,6	3200,6											1,99	202,0
27,00	97,2	3323,7											2,07	216,8

Tab. 38: Pressure loss at 30 K FibreFlex measurement 75-160

PRESSURE LOSS AT 20 K

HeatFlex

PRESSURE LOSS MEDIUM PIPE HEATFLEX AT VL 80 °C AND RL 60 °C

TYP:		25		32		40		50		63			
Volume electricity [l/s]	[m³/h]	Performance at spread 20 K [kW]		25x2,3 v R [m/s] [Pa/m]		32x2,9 v R [m/s] [Pa/m]		40x3,7 v R [m/s] [Pa/m]		50x4,6 v R [m/s] [Pa/m]		63x5,8 v R [m/s] [Pa/m]	
		0,06	0,2	4,9	0,18	25,0							
0,07	0,3	5,7	0,21	32,7									
0,08	0,3	6,5	0,24	41,4									
0,09	0,3	7,4	0,28	50,9									
0,10	0,4	8,2	0,31	61,4									
0,11	0,4	9,0	0,34	72,7									
0,12	0,4	9,8	0,37	84,8									
0,13	0,5	10,6	0,40	97,8	0,24	29,4							
0,14	0,5	11,5	0,43	111,6	0,26	33,6							
0,15	0,5	12,3	0,46	126,2	0,28	37,9							
0,16	0,6	13,1	0,49	141,7	0,30	42,5							
0,18	0,6	14,7	0,55	175,0	0,33	52,4							
0,20	0,7	16,4	0,61	211,5	0,37	63,2							
0,22	0,8	18,0	0,67	251,1	0,41	75,0							
0,24	0,9	19,6	0,73	293,9	0,45	87,6							
0,26	0,9	21,3	0,80	339,7	0,48	101,1	0,31	35,3					
0,28	1,0	22,9	0,86	388,6	0,52	115,5	0,34	40,3					
0,30	1,1	24,5	0,92	440,5	0,56	130,8	0,36	45,6					
0,35	1,3	28,6	1,07	583,4	0,65	172,7	0,42	60,0					
0,40	1,4	32,7	1,22	744,8	0,74	219,9	0,48	76,3					
0,45	1,6	36,8	1,38	924,7	0,83	272,3	0,54	94,3	0,34	32,0			
0,50	1,8	40,9			0,93	329,9	0,60	114,1	0,38	38,6			
0,55	2,0	45,0			1,02	392,6	0,66	135,6	0,42	45,8			
0,60	2,2	49,1			1,11	460,4	0,72	158,8	0,46	53,6			
0,70	2,5	57,3			1,30	611,0	0,84	210,1	0,54	70,7			
0,80	2,9	65,5			1,48	781,4	0,96	268,1	0,61	90,1			
0,90	3,2	73,6					1,08	332,6	0,69	111,5	0,43	36,5	
1,00	3,6	81,8					1,20	403,6	0,76	135,1	0,48	44,1	
1,10	4,0	90,0					1,32	481,0	0,84	160,7	0,53	52,4	
1,20	4,3	98,2					1,44	564,7	0,92	188,4	0,58	61,3	
1,30	4,7	106,4							0,99	218,2	0,63	70,9	
1,40	5,0	114,6							1,07	249,9	0,67	81,2	
1,50	5,4	122,7							1,15	283,7	0,72	92,0	
1,60	5,8	130,9							1,22	319,5	0,77	103,5	
1,70	6,1	139,1							1,30	357,2	0,82	115,6	
1,80	6,5	147,3							1,38	397,0	0,87	128,4	
1,90	6,8	155,5							1,45	438,7	0,92	141,7	
2,00	7,2	163,7									0,96	155,7	
2,20	7,9	180,0									1,06	185,5	
2,40	8,6	196,4									1,16	217,7	
2,60	9,4	212,8									1,25	252,3	
2,80	10,1	229,1									1,35	289,3	
3,00	10,8	245,5									1,45	328,7	

Tab. 39: Pressure loss at 20 K HeatFlex measurement 25–63

Material values water for
 Pressure loss calculations R [Pa/m]
 - spec. Heat capacity: 4185 J/(kgK)
 - middle spec. density: 977,66 kg/m³
 middle kin. viscosity: 3,29357 * 10⁻⁷ m²/s

recommended flow rate v [m/s]
 - House connection between 0,4-0,8 m/s
 reduced flow rate to avoid noise in residential buildings
 - Main continuous load 1,5 m/s
 - Main short load 2,0 m/s

PRESSURE LOSS MEDIUM PIPE HEATFLEX AT VL 80 °C AND RL 60 °C

TYP:		75		90		110		125		140		160		
Volume electricity [l/s]	[m ³ /h]	Performance at spread 20 K [kW]	75x6,8 v [m/s]	R [Pa/m]	90x8,2 v [m/s]	R [Pa/m]	110x10 v [m/s]	R [Pa/m]	125x11,4 v [m/s]	R [Pa/m]	140x12,7 v [m/s]	R [Pa/m]	160x14,6 v [m/s]	R [Pa/m]
2,40	8,6	196,4	0,81	91,4	0,56	37,9								
2,60	9,4	212,8	0,88	105,8	0,61	43,8								
2,80	10,1	229,1	0,95	121,2	0,66	50,2								
3,00	10,8	245,5	1,01	137,6	0,71	56,9								
3,30	11,9	270,0	1,11	164,0	0,78	67,7								
3,50	12,6	286,4	1,18	182,8	0,82	75,5								
3,80	13,7	311,0	1,28	212,8	0,89	87,7								
4,00	14,4	327,3	1,35	234,0	0,94	96,4								
4,30	15,5	351,9	1,45	267,5	1,01	110,1	0,68	41,3						
4,50	16,2	368,2	1,52	291,0	1,06	119,7	0,71	44,9						
4,80	17,3	392,8	1,62	328,1	1,13	134,9	0,75	50,5						
5,00	18,0	409,1	1,69	354,0	1,18	145,4	0,79	54,5						
5,30	19,1	433,7	1,79	394,5	1,25	161,9	0,83	60,6						
5,50	19,8	450,1	1,86	422,8	1,29	173,4	0,86	64,9						
5,80	20,9	474,6	1,96	466,8	1,36	191,3	0,91	71,5						
6,00	21,6	491,0	2,03	497,3	1,41	203,8	0,94	76,1						
6,30	22,7	515,5	2,13	544,9	1,48	223,1	0,99	83,3						
6,50	23,4	531,9	2,20	577,7	1,53	236,4	1,02	88,2						
7,00	25,2	572,8			1,65	271,3	1,10	101,1	0,85	54,4				
7,50	27,0	613,7			1,76	308,5	1,18	114,9	0,91	61,7				
8,00	28,8	654,6			1,88	348,0	1,26	129,5	0,98	69,5				
8,50	30,6	695,6			2,00	389,8	1,34	144,8	1,04	77,7				
9,00	32,4	736,5			2,12	433,8	1,41	161,0	1,10	86,4				
9,50	34,2	777,4			2,23	480,0	1,49	178,1	1,16	95,5				
10,00	36,0	818,3					1,57	195,9	1,22	105,0	0,97	60,0		
10,50	37,8	859,2					1,65	214,5	1,28	114,9	1,02	65,6		
11,00	39,6	900,1					1,73	234,0	1,34	125,3	1,07	71,5		
11,50	41,4	941,0					1,81	254,2	1,40	136,0	1,11	77,6		
12,00	43,2	982,0					1,89	275,2	1,46	147,2	1,16	84,0		
12,50	45,0	1022,9					1,96	297,1	1,52	158,8	1,21	90,6		
13,00	46,8	1063,8					2,04	319,7	1,58	170,9	1,26	97,4		
13,50	48,6	1104,7					2,12	343,1	1,65	183,3	1,31	104,4		
14,00	50,4	1145,6					2,20	367,3	1,71	196,2	1,36	111,7	1,04	58,5
14,50	52,2	1186,5							1,77	209,5	1,41	119,3	1,08	62,4
15,00	54,0	1227,4							1,83	223,2	1,45	127,0	1,12	66,4
16,00	57,6	1309,3							1,95	251,8	1,55	143,2	1,19	74,9
17,00	61,2	1391,1							2,07	282,1	1,65	160,4	1,27	83,8
18,00	64,8	1472,9							2,19	314,0	1,75	178,4	1,34	93,2
19,00	68,4	1554,8									1,84	197,4	1,41	103,0
20,00	72,0	1636,6									1,94	217,3	1,49	113,3
21,00	75,6	1718,4									2,04	238,1	1,56	124,1
22,00	79,2	1800,3									2,13	259,8	1,64	135,4
23,00	82,8	1882,1									2,23	282,4	1,71	147,1
24,00	86,4	1963,9											1,79	159,2
25,00	90,0	2045,7											1,86	171,9
26,00	93,6	2127,6											1,93	185,0
27,00	97,2	2209,4											2,01	198,5

Tab. 40: Pressure loss at 20 K HeatFlex measurement 75–160

PRESSURE LOSS AT 30 K

HeatFlex

PRESSURE LOSS MEDIUM PIPE HEATFLEX AT VL 80 °C AND RL 50 °C

TYP:		25		32		40		50		63		
Volume electricity		Performance at spread 30 K [kW]	25x2,3		32x2,9		40x3,7		50x4,6		63x5,8	
[l/s]	[m ³ /h]		v	R	v	R	v	R	v	R	v	R
			[m/s]	[Pa/m]	[m/s]	[Pa/m]	[m/s]	[Pa/m]	[m/s]	[Pa/m]	[m/s]	[Pa/m]
0,06	0,2	7,4	0,18	25,9								
0,07	0,3	8,6	0,21	33,9								
0,08	0,3	9,8	0,24	42,8								
0,09	0,3	11,1	0,28	52,7								
0,10	0,4	12,3	0,31	63,4								
0,11	0,4	13,5	0,34	75,1								
0,12	0,4	14,8	0,37	87,6								
0,13	0,5	16,0	0,40	100,9	0,24	30,4						
0,14	0,5	17,2	0,43	115,1	0,26	34,7						
0,15	0,5	18,5	0,46	130,2	0,28	39,2						
0,16	0,6	19,7	0,49	146,1	0,30	43,9						
0,18	0,6	22,2	0,55	180,3	0,33	54,1						
0,20	0,7	24,6	0,61	217,8	0,37	65,2						
0,22	0,8	27,1	0,67	258,4	0,41	77,3						
0,24	0,9	29,5	0,73	302,3	0,45	90,3						
0,26	0,9	32,0	0,80	349,3	0,48	104,2	0,31	36,4				
0,28	1,0	34,5	0,86	399,3	0,52	119,0	0,34	41,6				
0,30	1,1	36,9	0,92	452,5	0,56	134,6	0,36	47,0				
0,35	1,3	43,1	1,07	598,7	0,65	177,7	0,42	61,9				
0,40	1,4	49,2	1,22	763,8	0,74	226,1	0,48	78,6				
0,45	1,6	55,4	1,38	947,6	0,83	279,8	0,54	97,1	0,34	32,9		
0,50	1,8	61,6			0,93	338,7	0,60	117,4	0,38	39,8		
0,55	2,0	67,7			1,02	402,9	0,66	139,4	0,42	47,2		
0,60	2,2	73,9			1,11	472,2	0,72	163,2	0,46	55,2		
0,70	2,5	86,2			1,30	626,0	0,84	215,8	0,54	72,8		
0,80	2,9	98,5			1,48	800,0	0,96	275,1	0,61	92,6		
0,90	3,2	110,8					1,08	341,1	0,69	114,6	0,43	37,5
1,00	3,6	123,1					1,20	413,6	0,76	138,7	0,48	45,4
1,10	4,0	135,4					1,32	492,6	0,84	165,0	0,53	53,9
1,20	4,3	147,7					1,44	578,1	0,92	193,3	0,58	63,0
1,30	4,7	160,0							0,99	223,7	0,63	72,9
1,40	5,0	172,3							1,07	256,2	0,67	83,3
1,50	5,4	184,7							1,15	290,7	0,72	94,5
1,60	5,8	197,0							1,22	327,2	0,77	106,2
1,70	6,1	209,3							1,30	365,8	0,82	118,6
1,80	6,5	221,6							1,38	406,3	0,87	131,7
1,90	6,8	233,9							1,45	448,9	0,92	145,3
2,00	7,2	246,2									0,96	159,6
2,20	7,9	270,8									1,06	190,0
2,40	8,6	295,4									1,16	222,9
2,60	9,4	320,1									1,25	258,3
2,80	10,1	344,7									1,35	296,0
3,00	10,8	369,3									1,45	336,2

Tab. 41: Pressure loss at 30 K HeatFlex measurement 25-63

Material values water for
Pressure loss calculations R [Pa/m]
- spec. Heat capacity: 4185 J/(kgK)
- middle spec. density: 980,49 kg/m³
- middle kin. viscosity: 3,53238 * 10⁻⁷ m²/s

recommended flow rate v [m/s]
House connection between 0,4-0,8 m/s
reduced flow rate to avoid noise in residential buildings
- Main continuous load 1,5 m/s
- Main short load 2,0 m/s

PRESSURE LOSS MEDIUM PIPE HEATFLEX AT VL 80 °C AND RL 50 °C

TYP:		75		90		110		125		140		160		
Volumenstrom [l/s]	[m ³ /h]	Leistung bei Spreizung 30 K [kW]	75x6,8		90x8,2		110x10		125x11,4		140x12,7		160x14,6	
			v	R	v	R	v	R	v	R	v	R	v	R
2,40	8,6	295,4	0,81	93,8	0,56	38,9								
2,60	9,4	320,1	0,88	108,5	0,61	45,0								
2,80	10,1	344,7	0,95	124,3	0,66	51,5								
3,00	10,8	369,3	1,01	141,0	0,71	58,4								
3,30	11,9	406,2	1,11	168,0	0,78	69,5								
3,50	12,6	430,9	1,18	187,1	0,82	77,4								
3,80	13,7	467,8	1,28	217,7	0,89	89,9								
4,00	14,4	492,4	1,35	239,3	0,94	98,8								
4,30	15,5	529,3	1,45	273,5	1,01	112,8	0,68	42,4						
4,50	16,2	554,0	1,52	297,5	1,06	122,6	0,71	46,1						
4,80	17,3	590,9	1,62	335,3	1,13	138,1	0,75	51,8						
5,00	18,0	615,5	1,69	361,7	1,18	148,8	0,79	55,8						
5,30	19,1	652,4	1,79	403,0	1,25	165,7	0,83	62,1						
5,50	19,8	677,1	1,86	431,7	1,29	177,4	0,86	66,5						
5,80	20,9	714,0	1,96	476,6	1,36	195,7	0,91	73,3						
6,00	21,6	738,6	2,03	507,6	1,41	208,3	0,94	78,0						
6,30	22,7	775,5	2,13	556,0	1,48	228,0	0,99	85,3						
6,50	23,4	800,2	2,20	589,4	1,53	241,6	1,02	90,3						
7,00	25,2	861,7			1,65	277,2	1,10	103,5	0,85	55,7				
7,50	27,0	923,3			1,76	315,1	1,18	117,5	0,91	63,2				
8,00	28,8	984,8			1,88	355,3	1,26	132,4	0,98	71,2				
8,50	30,6	1046,4			2,00	397,8	1,34	148,1	1,04	79,6				
9,00	32,4	1107,9			2,12	442,5	1,41	164,6	1,10	88,4				
9,50	34,2	1169,5			2,23	489,6	1,49	182,0	1,16	97,7				
10,00	36,0	1231,0					1,57	200,1	1,22	107,4	0,97	61,4		
10,50	37,8	1292,6					1,65	219,1	1,28	117,5	1,02	67,1		
11,00	39,6	1354,1					1,73	238,9	1,34	128,0	1,07	73,1		
11,50	41,4	1415,7					1,81	259,5	1,40	139,0	1,11	79,4		
12,00	43,2	1477,2					1,89	280,9	1,46	150,4	1,16	85,9		
12,50	45,0	1538,8					1,96	303,1	1,52	162,3	1,21	92,6		
13,00	46,8	1600,3					2,04	326,1	1,58	174,5	1,26	99,6		
13,50	48,6	1661,9					2,12	350,0	1,65	187,2	1,31	106,8		
14,00	50,4	1723,4					2,20	374,6	1,71	200,3	1,36	114,2	1,04	59,8
14,50	52,2	1785,0							1,77	213,8	1,41	121,9	1,08	63,8
15,00	54,0	1846,5							1,83	227,8	1,45	129,8	1,12	68,0
16,00	57,6	1969,6							1,95	256,9	1,55	146,3	1,19	76,6
17,00	61,2	2092,7							2,07	287,7	1,65	163,8	1,27	85,6
18,00	64,8	2215,8							2,19	320,1	1,75	182,1	1,34	95,2
19,00	68,4	2338,9									1,84	201,4	1,41	105,2
20,00	72,0	2462,0									1,94	221,7	1,49	115,8
21,00	75,6	2585,1									2,04	242,8	1,56	126,7
22,00	79,2	2708,2									2,13	264,9	1,64	138,2
23,00	82,8	2831,3									2,23	287,9	1,71	150,1
24,00	86,4	2954,4											1,79	162,5
25,00	90,0	3077,5											1,86	175,4
26,00	93,6	3200,6											1,93	188,7
27,00	97,2	3323,7											2,01	202,5

Tab. 42: Pressure loss at 30 K HeatFlex measurement 75–160

PROJECT Planning

PROJECT PLANNING

The expertise of **RK Infra** can be an asset to every project. There is no standardized heat network. Every project is individually considered. Following is a small overview of the heat network project planning. The letters in bold are going to be further explained in the subsequent paragraphs.

Pipe dimensioning requires a route plan to be made.

This is where the route and the buildings to be connected are laid out. In order to be able to carry out the pipe sizing, the **connection power** in the buildings must have been settled.

While considering **simultaneity**, the pipe sizing will be determined according to a required flow rate and permissible **pressure loss**. When using a decentralized **buffer storage system**, the heat peaks in the building will intercept. This way, the pipe sizing will get smaller, the **heat loss** decreased, and the costs of a heat network reduced. Further reductions in heat loss will be achieved through pipes with a PLUS-insulation.

The volume flow and pipe friction pressure loss must be overcome before the **pump design** has been made. Additionally, further resistances which could occur in the transfer and heating technology must be considered. The geodesic height difference has to be determined when selecting the compression level for the pipe parts and pipe system.

The investment costs with the depreciation period, the operating costs for the pumps and system parts as well as the heat loss and the energy production costs are included in the profitability calculation.

MEASUREMENT OF CONNECTED POWER

There are different calculation forms. In one of them, proof of energy requirements is being used, while in the other one we use the actual consumption of the last three years of the building type by type, year of construction, etc. On pages 74 and 75 you can find a questionnaire as a basis for assessing the needs of existing buildings.

After the assessment of the questionnaire and considering a number of full power hours (in a residential building this is on average 1500-2000 hours), the connected power is determined.

The use of a decentralized buffer storage system, the number of full load hours is higher and the connected power lower. This is because the buffer storage system absorbs heat peaks in the building.

Look at the graph.



Abb. 26: Charging and discharging behaviour of the buffer storage diffuser

PIPE DIMENSIONING FACTOR SIMULTANEITY

When applying this factor, the design performance will reduce the power rating for the piping. The more buildings are connected to the pipeline, the lower the simultaneity factor.

However, it should be noted that the following diagram is only used for existing residential buildings. This diagram cannot be used for buildings located in a strand, or for school buildings, nor any other large-scale consumer buildings. These large scales should be assessed separately. Furthermore, this diagram also cannot be used for new buildings because they have different behaviour.

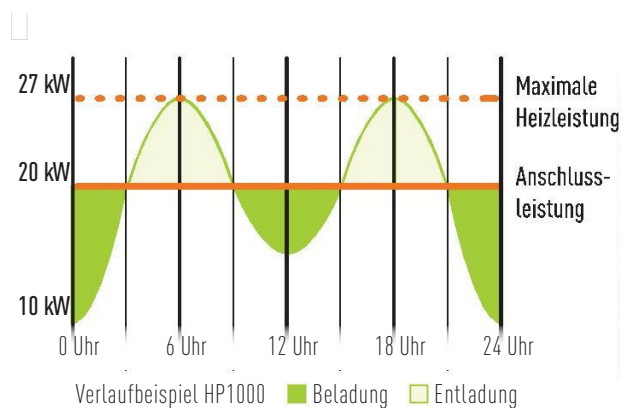
Only then can pipe sizing be created. Even when using a buffer storage system, the simultaneity has to be set differently because some of the heat peaks have already been intercepted throughout the building.

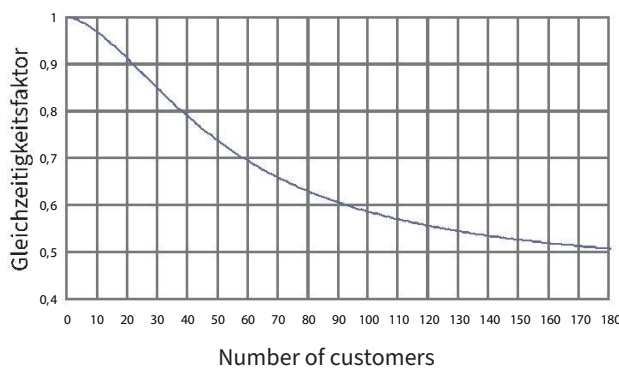

Diagram 1: Simultaneity of given building under the use of a transfer station

PIPE DIMENSIONING FACTOR PRESSURE LOSS

The tables on pages 30-37 can be used as a rough guide for simple pipe dimensioning. However, when doing a network calculation, the pipes need to be kept as small as possible.

This way the heat loss can be kept low for the entirety of the year. The price of electricity in the network pump can be relatively higher during a very short period during the cold time of the year. The reduction in network losses outweighs in most cases. The following diagram shows heat behaviour of a heat network.

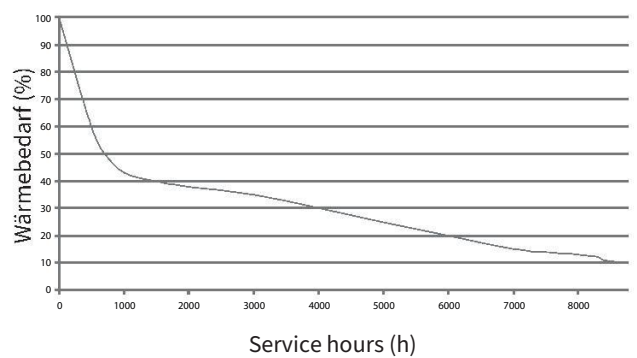

Diagram 2: Heating behaviour in a heating network

PIPE TYPE AND HEAT LOSS REDUCTION

When choosing the pipe type, considerations must be taken. Double pipes should be used if possible. In addition, the head loss through the PLUS pipes are additionally reduced. It is more economical to use one size smaller if a single pipe can be avoided. This conclusion has been reached following detailed calculations.

PROJECT Planning

PIPE DIMENSION AND BUFFER DIFFUSER SYSTEM

The following shows the advantages of a centralized buffer storage system compared to a transfer station with a central buffer system. Through the increase in full-service hours and the deployment of a decentralized buffer storage, the dimension of the pipe gets smaller.

This way, the radiation losses can be reduced by 40% (look at the calculations).

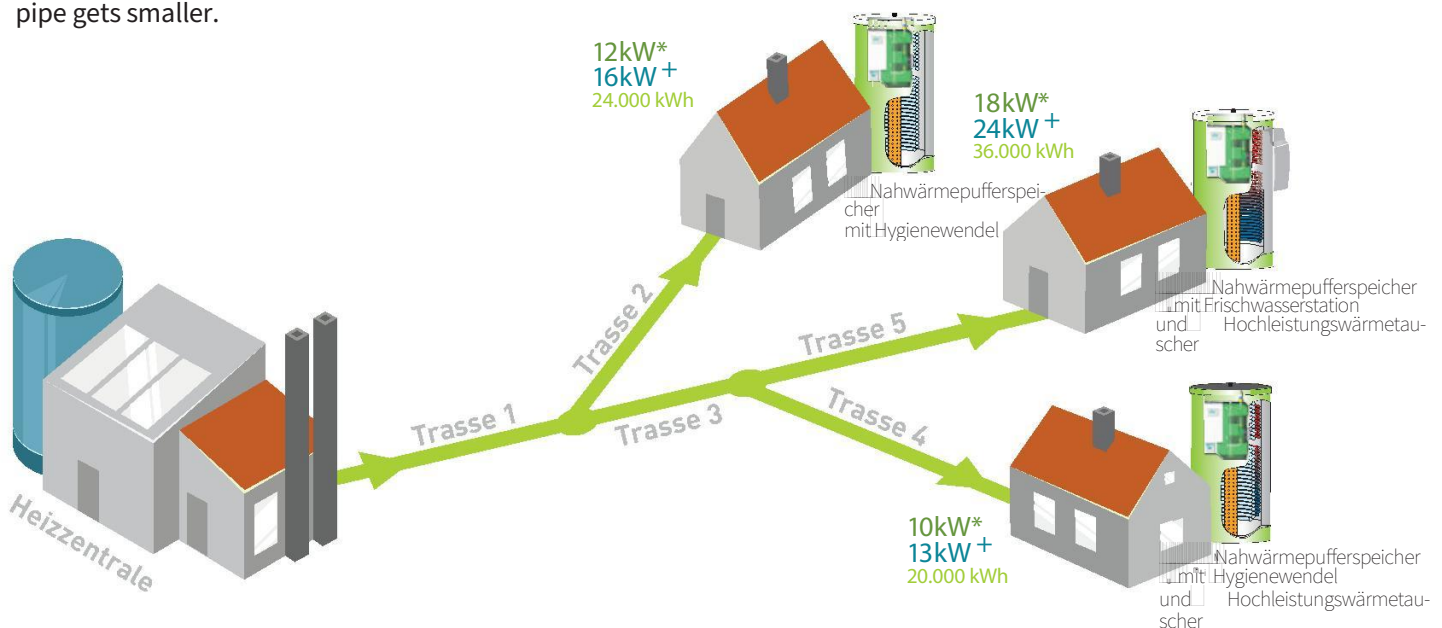

CENTRAL BUFFER STORAGE IN THE HEATING PLANT

	Route 1	Route 2	Route 3	Route 4	Route 5	Overall heat loss
Route length	50 m	21 m	33 m	24 m	19 m	15.135 kWh # Per year
Dimension	40+40/126	32+32/111	40+40/126	32+32/111	32+32/111	

Service temperatures: Summer 70/55 °C ; Winter 75/55 °C
 Pressure loss Δp 0,70 bar at 1500 Full service hours
 Tab. 43: Laying without buffer storage

DECENTRAL DISTRICT HEATING BUFFER IN BUILDINGS WITH BUFFER MANAGEMENT

	Route 1	Route 2	Route 3	Route 4	Route 5	Radiation losses
Route length	50 m	21 m	33 m	24 m	19 m	9.105 kWh # pro Jahr
Dimension	32+32/111	25+25/111	32+32/111	25+25/111	32+32/111	

Service temperatures: Summer 70/35 °C ; Winter 75/50 °C
 Summer charge: 1x pro day + fresh water station or Hygiene spiral
 Pressure loss Δp 0,70 bar at 2000 full service hours
 Tab. 44: Laying with buffer storage

*With buffer storage: 2000–2200 full service hours
 *without buffer storage: 1500–1700 full service hours

#The total heat loss must be considered on a case-by-case basis.

PUMP DESIGN

Calculation programs from the manufacturer are used for the pump design. To determine energy costs, one must enter the annual heating load curve and the operating time in the respective performance level. Yearly energy usage should amount to $> 0,8$ % of the yearly consumed heating energy.

GEODETTIC HEIGHT DIFFERENCE

To determine the pressure level of the pipes and fittings, the geodetic height difference must be assessed. When the height difference is for example 30m, and the economic pressure drop 4,5 bar, the necessary overpressure of the heating station or the highest transfer station of 1,5 bar, as well as the additional pressure of other plant parts of 0,4 bar, the overall pressure load of the pipe ends up from 9,4 bar. This is how the pipe type **FibreFlex** was chosen. When the heating station lies at the deepest point, the heating station would have a resting pressure load from 4,5 bar. This way, the plant parts have to be layed in PN 6. If the plant parts could not be bypassed with PN 3, a system division through the heat exchanger can be used. If the heating station reaches the highest point, the PN 3 can be executed.

ECONOMIC CALCULATIONS

This can only be achieved through a backed-up plan. The greater the heat consumption, the better it is to show the profitability. If the heat consumption is in the range of 500 kWh/ pipeline meter or less, profitability can still be reached by using selected components and optimal dimensioning.

PRESSURE LOSS

The determination of the pressure loss of the **FibreFlex / HeatFlex-pipe** at a spread from 20 K or 30 K are on the pages 30-37 on the corresponding tables.

LAYING/ STORAGE

RK Infra Rohrsysteme

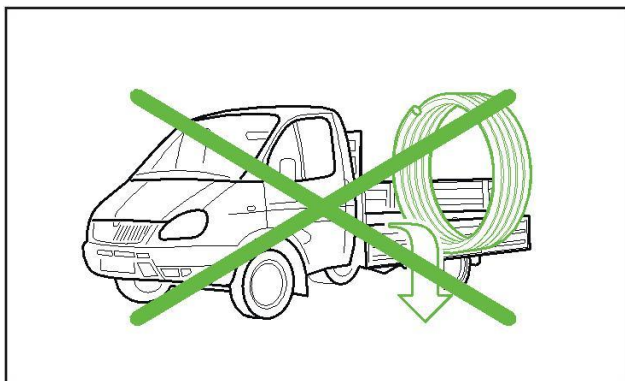
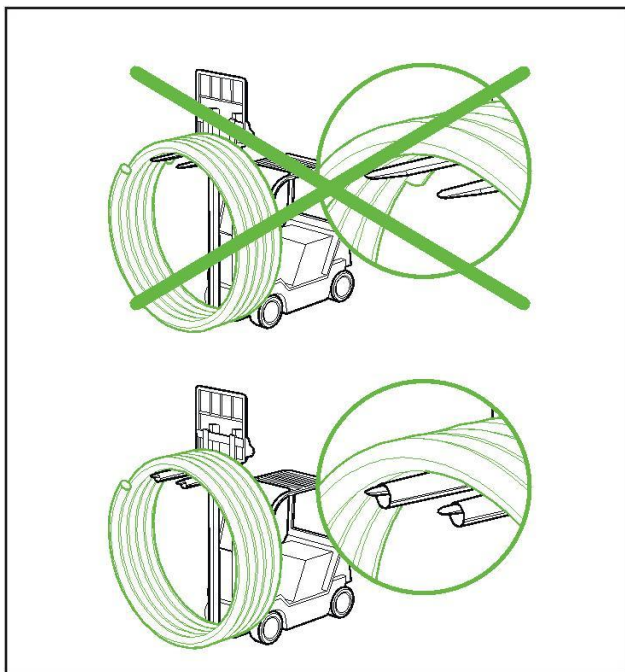
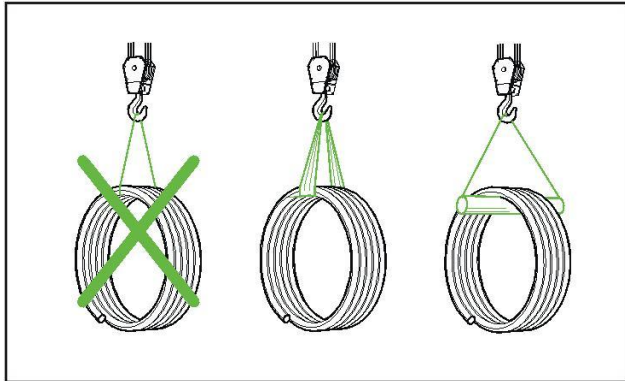

UNLOADING

In general

- When loading and unloading the coils, be careful not to damage the outer jacket.
- For unloading, use a slip made from synthetic material which is at least 50mm wide. Do not use steel cables, chains, wires or round ropes. Lift the coils completely when loading and unloading and do not lift them over the floor or other texturized surfaces.
- When using forklifts, use the provided angular forks with a round and soft protection (e.g. a piece of PE pipe or similar). Be careful that the coils do not slip out of the forks.

STORAGE

In general

- For longer storage periods, store coils horizontally on a flat surface. For an inclined surface, secure it against slipping with suitable means.
- Choose a coil storage location which cannot get flooded.
- Flat storage area without sharp stones or other sharp objects in the ground.
- For additional protection, store coils flat on wooden pallets, wooden planks or sandbags.
- Do not open the lashing straps of the coils during its transport and storage.
- For protection against dust, dirt and splash water, close the ends of the coils with dust protection caps.

TYPES OF LAYING

Description

TYPES OF LAYING

The laying of a pipe can be done in an open or closed construction zone.

Closed (trenchless) construction sites are the following:

- Plowing
- Horizontal drilling
- Shooting (earth rocket)
- Pressing (steel pipe)

Open construction sites are:

- Milling
- Open trenches with excavator

TRENCHLESS METHOD:

They are mainly used for crossings from roads, railway lines or bodies of water. The great advantage of the trenchless method is that the existing surface is not affected or damaged and traffic can continue unobstructed. All trenchless procedures have a start and target pit.

PRESSING FROM A STEEL PIPE AND THE COLLECTION OF HEAT CONDUCTION

Suitable steel pipe selections are pressed into the ground with the help of a press and pushed forward hydraulically from the starting pit towards the target pit. Depending on the length of the pressing, there are several steel tube rods to be welded together. With this method, there is no displacement of the soil. The soil that is inside the steel tube is mechanically removed with an auger or flushed out with water. The heat pipe can then be pulled or pushed through the now freed-up steel pipe.

PLOWING

Plowing is one of the more rational and economical methods of laying pipes and cables. Due to the technical complexity, this method is however only worthwhile for a route length of more than 500m.

Advantages of the plow laying method:

- High daily output possible up to 3000 to 5000m (depending on device type, ground conditions, etc.)
- Minor disturbance and damage to the ground
- Time and cost-effective as only one operation is required

The soil and possibly existing stones can be displaced through the propulsion of the plow laying method. The ground can also be cut through a slit. The soil structure remains unchanged.

The pipe is buried and inserted in the ground in the same operation. The ground heap caused by plowing is rolled in. When laying a pipe through plowing, it is possible to lay several lines and route warning tapes in one operation.

Depending on the type of device used, the maximum laying depths of up to 2,50m can be carried out with this method.



Abb. 27: Laying by plowing

LAYING TYPES

Description

MILLING

A variant of the open construction is laying in a milled pipe trench. Unlike plowing, the milling process can also be used on stony or rocky soil types. Of course, the installation performance significantly depends on the prevailing floor type. In principle, however, it is lower than the laying used in the plowing method.

When milling, a distinction should be made between the method with the installation box and the method without it. The procedure with the installation box stops allows for an automated process. Here, a piping trench is produced with the so-called milling and laying unit. After that, the pipe is laid with the help of the built-in box. The backfilling and compaction take place afterwards with the help of the so-called backfill and compaction unit in one step. In contrast, the method without the installation box, the milled stored material is put aside and filled again in the next step.

Depending on the device type, trenches with a width between 20-60cm are opened. The depths are in the range of up to 1,20m. during milling, the soil is mixed and stored along the side of the pipe trench. As a rule, the pipe trench is backfilled with this excavation material.

The milling process is detailed in the DVGW GW 324 leaflet described in more detail.



Abb. 28: Milling without installation box

FLUSH DRILLING RIG

Horizontal flush drilling rigs work with traction and thrust, torque (rotation), flushing and more dynamic clout. Bentonite cools, lubricates and strengthens the bore. From the starting pit, a so-called pilot bore is drilled with a drill head attached to a drill rod in the direction of the target pit.

Due to the flexibility of the linkage and the controllability of the drill head, the direction of the flushing rig changes. At the beginning, the hole is usually at a slightly slanted angle and then runs downwards into a sharper arc towards the target pit where it turns upwards. In the target pit, the drill head is replaced by a so-called scraper.

Since the scraper has a larger diameter than the drill head, it widens when retracting the pilot while simultaneously compacting the walls of the hole. If no further expansion steps are necessary, one or more pipes will be attached and inserted into the flushing hole. The maximum length of the insertion depends on the measured tensile force at the pulling head. Then, the maximum allowed tensile force of the pipe material cannot be exceeded. Common horizontal drilling rigs reach depths of 2 to 4 m, diameters up to 30 cm and lengths of 150m or more.

The achievable bending radii are not determined by the pipe, but by the set drill rods.



Abb. 29: flush drilling rig with pipes in the launch pit

SHOOTING (EARTH ROCKET)

This method uses a pneumatically operated soil displacement hammer. It is called an earth rocket because of its shape.

By propelling the displacement hammer, the compressed air creates a cavity under the ground. The ground is repressed in the surrounding soil. Any boulders or soil material do not have to be removed from the cavity. This is why this method can only be used if the existing soil has appropriate qualities for displacement and a consistency that is not too hard. Due to the displacement principle, the road surface can be raised, depending on the depth of the earth rocket.

To avoid budging on the surface, a coverage dimension of at least 10 times the diameter of the earth rocket's walls is recommended. The range usually around 15m, but depending on the system used, can reach up to 40m. It should be noted that the earth rocket cannot be steered or controlled during the process and can therefore go astray on the way. Finding the location of the rocket is possible with appropriate equipment.

The pipes which are layed in the cavity both straightaway or later cannot be connected with any sleeves.

The soil displacement method is described in ATV-A 125 or GW 304.

OPEN METHODS

IN OPEN TRENCHES

The classic method of laying pipes is laying them in open trenches. After removing the surface, the trench is opened with suitable equipment, like an excavator. A hand shaft has built-in components which could help in times of obstacles. Until 1,25m in depth, no embankment of the ditch or shoring is necessary. The clear width of a trench with no without space for construction at this depth is 0,60m. For laying an open trench, the coil should be on an uncoiling device when assembling. After that, the pipe along the pipe trench is layed.

When digging the bottom of the trench, a sand bed is levelled.



Abb. 30: open pipe trench with an uncoiling device

The sand bed is usually at least 10 cm thick. If the bottom of the ditch consists of rocky or stony subsoil, it should be excavated at least 15cm deeper. The corresponding excavation will be replaced through a stone-free and compactable layer.

Under no circumstances should the pipe be pulled into the trench over sharp-edged objects or stony ground!

The sand coating of the pipes is at least 10cm on all sides. Only stone-free and compactable material is used for the bottom of the trench and the pipe bedding and coating. Sand 0/4 is preferably used (no crushed sand!).

The trench is immediately filled after the installation of the lines and completion of the assembly and calibration work. When backfilling, care must be taken to ensure that the pipes are also completely covered with material in the gusset area and that no cavities are formed. After the pipe zone has been backfilled, the pipe trench must be filled and levelled to a height of aprox. 0,3m above the pipe crest. The route warning tape is to be layed out on this balanced layer.

Mechanical compaction equipment may only be used from an overlap of 30cm. After the pipe trench has been backfilled properly, the corresponding surfaces are restored.

LAYING TYPES

Description/ laying

TRENCH WIDTH

According to DIN 4124, these are the following minimum widths:

trench depth to	light min. width
0,70 m	0,30 m
0,90 m	0,40 m
1,00 m	0,50 m
1,25 m	0,60 m

Tab. 45: min. Trench width

The determination of the trench width is dependent on the laying out of the lower edge of the cable. If, for example, a sand bed is dug deeper and enters the soil, this depth is applicable.

MINIMUM DISTANCES FROM OTHER LINES/ THIRD PARTY INSTALLATIONS

The laying distances of the local heating pipe system to other external/ supply lines conforms to the corresponding information in the regulations of the DVG W400 and AGFW. These values only apply if no other local/ regional regulations (water suppliers, energy suppliers, etc.) are applicable.

Min. Laying distance according to DVGW W400

Supply line type	Crossing lines Or parallel laying < 5 m	Parallel laying > 5 m
Gas line	0,2 m	0,4 m
Water line*	1,0 m	1,0 m
1 kV, Signal and measuring cable	0,3 m	0,3 m
10 kV - 30 kV cable	0,6 m	0,7 m
several 30 kV-cables or cable over 60 kV	1,0 m	1,5 m

Tab. 46: Minimum laying distance to other supply lines

- * According to DVGW W400, no negative influence is to be expected in drinking from water pipes if the distance to district heating and thermal lines is at least 1m. If the distance is smaller, the individual circumstances must be evaluated.

If it is not possible to maintain the specified minimum distances in the area of narrow passes, these can be passed by using an intermediate layer of suitable materials.

LAYING

Operating/ laying assembly instructions

OVERALL

All pipes are always protected against mechanical damage when in storage, transport and during processing and laying by taking appropriate measures for careful treatment.

Pointed loads and contact with sharp objects is to be avoided. Mechanical damage and deformation cause leaks in the local heating network, so a suitable specialist should be employed for processing and laying of the pipes. Professional supervision during construction should be ensured.

The currently valid technical rules as well as the additional technical regulations of the relevant utility company or customer must be observed.

LAYING

Protection from dust, dirt and water

The ingress of dust, dirt and splashing water must always be avoided when handling the pipes on the construction site. Lost dust protection caps must be replaced immediately.

Protection from mechanical damage

Proceed with suitable equipment on the construction site. Do not go over sharp-edged objects or sharp edges with the pipes. Do not bend them. Damage can lead to a leak in the local heating networks.

Laying temperature

If the temperature is <10°C, the pipe bundle must be preheated in the hall. If the bending radius according to table 49 (p. 56) is to be implemented at freezing temperatures, the outer jacket on the pipe trench should be preheated on, e.g. a soft burner flame. At temperatures below -10°C, laying is discouraged.

TRENCH PROFILE

with minimum coverage

RK Infra pipe systems

Pipe type DUO
1 pipe



Abb. 31: trench cross-section 1 pipes

Pipe type UNO
2 pipes

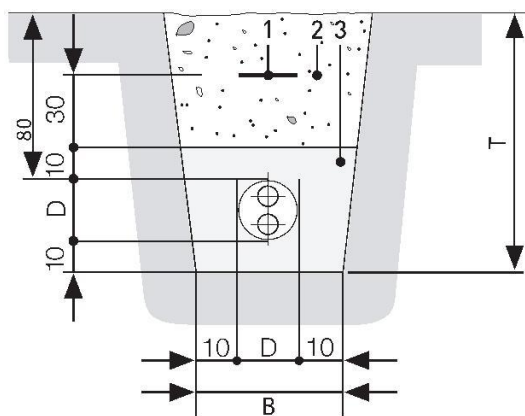

Abb. 32: trench cross-section 2 pipes

Pipe type UNO
4 pipes

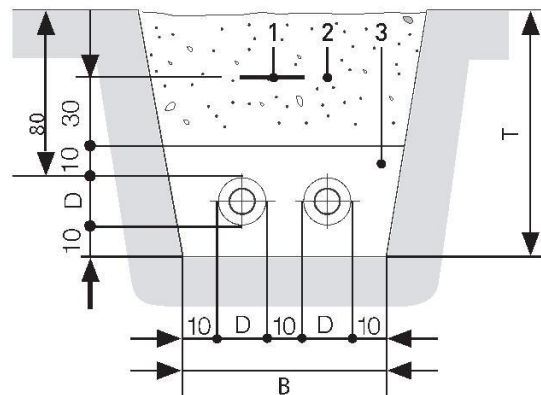

Abb. 33: trench cross-section 3 pipes

- 1 Route warning tape
- 2 Compact excavated material
- 3 Sand, corn size max. 0-4 mm

info in cm

SLW 30 = 300 kN Total load according to DIN 1072; for exposure to higher traffic roads (z.B. SLW 60) is a load-distributing superstructure according to RstO 12 is required.

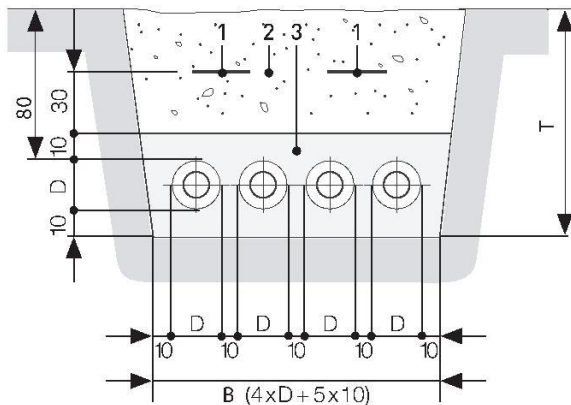
Without traffic load, the minimum trench depth T can be reduced by 20 cm.

Maximum laying depth – larger laying depths require our approval!

CONNECTION TECHNOLOGY

HeatFlex

CONNECTION TECHNOLOGY

The HeatFlex medium pipes are connected using the proven method of a press connection with a sliding sleeve.

This creates a fast, safe and durable tight connection. To produce the press connection, hydraulic standard press tools for PE-Xa pipes are used.

For the different connection situations, there are corresponding press connectors:



PE-Xa – PE-Xa press connectors
for the connection of two PE-Xa pipes



PE-Xa T-piece press connectors
for branch line productions



PE-Xa – steel press connectors
for the connection PE-Xa pipe with steel pipe

There is a wide variety of alternatives in straight and reduced versions available.

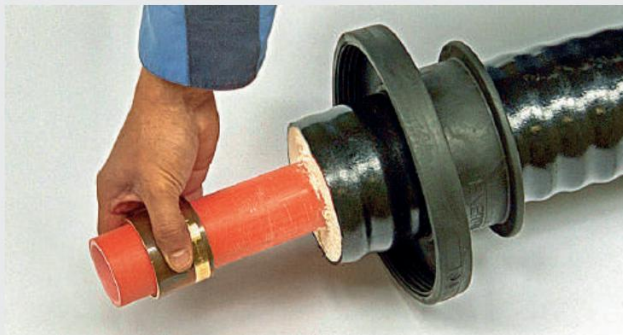

Push on the sliding sleeve.

Warning: compression sleeve must protrude towards the supporting body.

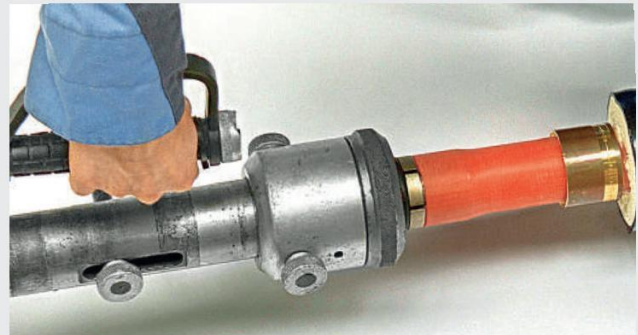

Expand pipe with expansion tool. Then turn the expanding tool for 30 degrees and repeat the expansion.

Compression sleeve technology (SST)

With the compression sleeve technology (SST), a compression sleeve is pushed loosely into the medium pipe.

Then, the medium pipe is widened at the open end with a special tool – the so-called expansion tool.

The fitting can now be pushed into the expanded pipe end as far as it will go.

To slide the compression sleeve onto the fitting, use a press tool. The sliding sleeve which is loosely pushed into the medium pipe is now pushed axially over the pipe and the support body of the pipe is pushed as well.

The plastic of the medium pipe is pressed into the grooved profile of the fitting and is fixed in place.

There is an equal pressure of the pipe on the fitting.

Additional sealing measures such as e.g. an additional elastomeric sealing ring, are not necessary. The PE-Xa material of the medium pipe acts as a seal on its own.

PROS:

- > Safe and quick assembly
- > Independent from the weather
- > No re-tightening of the connection is necessary, so the pressure can be changed immediately
- > Comes without extra sealing elements (e.g. hemp, O-rings,...)
- > medium pipes are not widened when connected, so there is virtually no cross-sectional reduction → negligible pressure loss

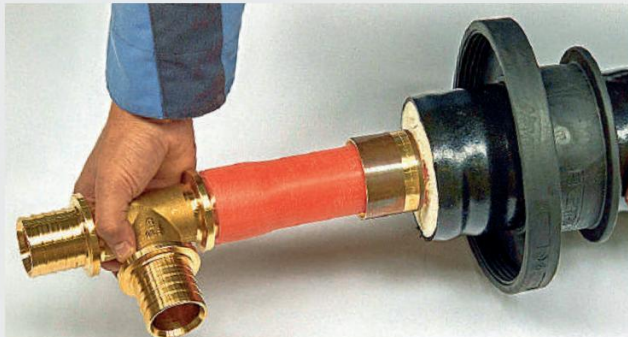

Insert the support body up to the last bar.

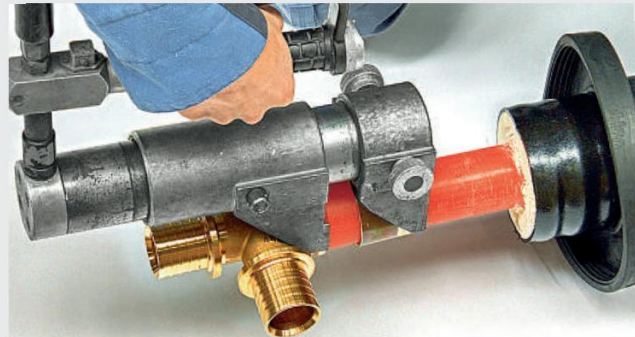

Pull the sliding sleeve over the body protector/ support. The connection is good if the medium pipe covers the last bar on the support body.

GUIDANCE

Squeezing medium pipe PE-Xa

Overall

More often, new subscribers are to be connected to an existing local heating network. One way to do this is by squeezing the local heating line. In the area of the planned connection, the line is squeezed off with the help of a squeeze device, then separated. At this point, the T-piece for the branch is pressed in. the general conditions or prerequisites and the process of squeezing are listed in the DVGW leaflet GW 332 (as of 2001-09). If the specifications are observed, squeezing has no negative impact on the medium pipe. The recommended medium pipe diameter is 160 mm and the maximum wall thickness is 10 mm. the distance from the pinch point to the next connection or another pinch point must be 3-5 times the outside diameter of the pipe.

Ideally, the outside temperature should be +10°C, or at least 5°C, since lower temperatures have an unfavorable effect on the formation (risk of deformation) of the PE pipe and a risk of cracking arises.

An 'underfined' squeezing of the pipe until a seal is achieved is not permitted. If the pipe is 'squeezed', the corresponding pipe section must be replaced. So that there is no damage to it on the PE line, the extent of crushing (degree of squeezing) should not have a value smaller than 0.8. The degree of squeezing is the ratio between the distance between the clamps of the squeezer and twice the wall thickness of the tube.

$$\text{Squeezing degree} = \frac{\text{Minimum distance of the clamps of the squeezing device}}{2 \times \text{wall thickness of the pipe}}$$

Notice: degree of squeezing ≥ 0,8

Medium pipe HeatFlex			Min. Distance between the pinch rollers [mm]
AD	x	s [mm]	
25	x	2,3	3,7
32	x	2,9	4,6
40	x	3,7	5,9
50	x	4,6	7,4
63	x	5,8	9,3
75	x	6,8	10,9
90	x	8,2	13,1
110	x	10,0	16,0

Tab. 47: HeatFlex pipe squeezing degree 0,8

Medium pipe FibreFlex			Min. Distance between the pinch rollers [mm]
AD	x	s [mm]	
25	x	2,2	3,5
32	x	2,5	4,0
40	x	2,8	4,5
47,6	x	3,6	5,8
58,5	x	4,0	6,4
69,5	x	4,6	7,4
84	x	6,0	9,6
101	x	6,5	10,4
116	x	6,8	10,9
127	x	7,1	11,4
144	x	7,5	12,0

Tab. 48: FibreFlex pipe squeezing degree 0,8

Safety notice

Due to the pressure and the high temperature of the heating water, there is a risk of scalding! Before the squeezing, separate the line pressure and the temperature in the heating network, if possible.

Work steps

1. Expose and clean the medium pipe in the area of intended pinching.

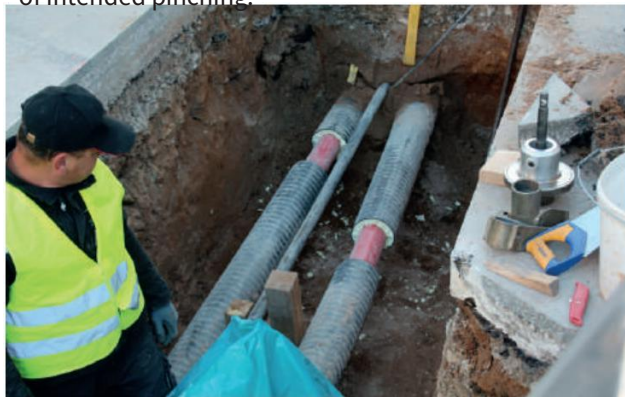

2. attach the squeezing device on the flow and return at the individual lines.



Or on a double line.



3. After separating the local heating pipe at the new connection point, the sleeve sealing rubbers **HeatClick I-Sleeves** are pushed on for later insulation of the pinch points.



4. release the squeeze device. A reshaping of the crushed medium pipe by means of appropriate aids is usually not required. The medium pipe goes back into its original form because of the memory-effect.



5. Close the isolation at the squeeze points with the **HeatClick I-sleeves**.



Finally, the pinch point is marked and noted in the building plan so that no one creates another squeeze at this point.

LAYING OF THE PIPES

Laying help

Description

The laying aid for straightening pipes consists of the following individual parts:

- 1 galvanized pipe straightener with rubber claws and straps
- 2 round slings
- 1 chain hoist



The claws are attached to the pipe with the straps:

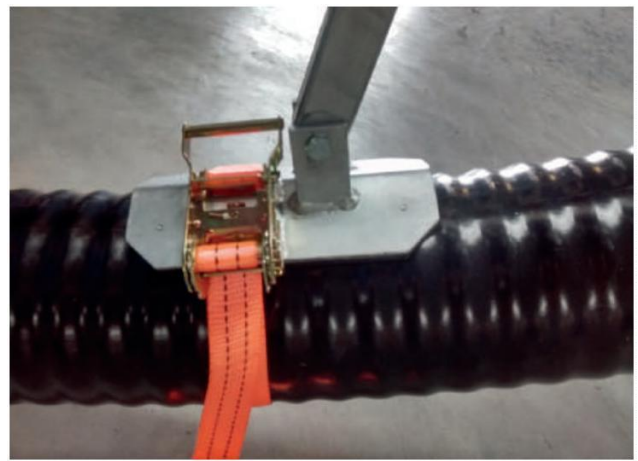

The round sling is placed in the middle below the pipe straightener and guided around the pipe.

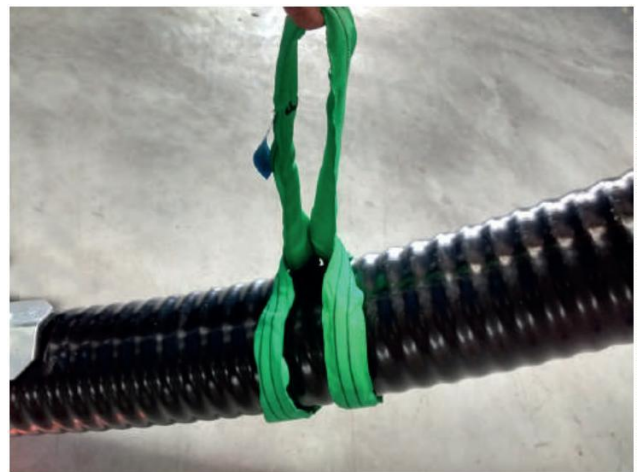

Assembly



FIRST WAY:

The pipe end is bent upwards.

The laying aid is angled at approx. 90°C and placed on the bent pipe end provided.



The chain hoist is hooked into the upper bolt on the laying aid and into the round sling.

Tighten the chain hoist using the ratchet. Clamp until the pipe is straight.

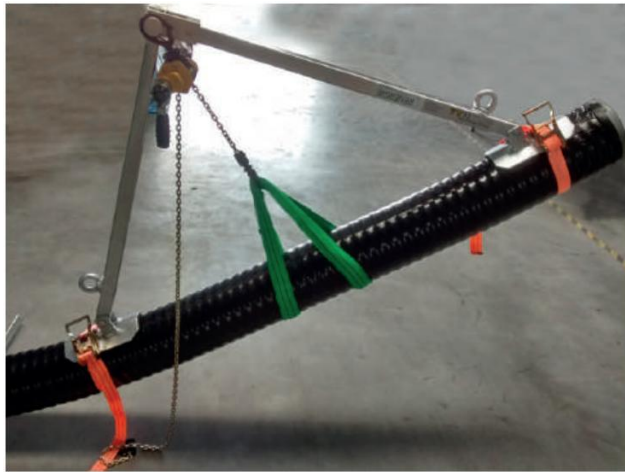

The claws are attached to the pipe with the straps.

Attach a round sling to the pipe at a distance of about 1m to the right and left of the laying aid.

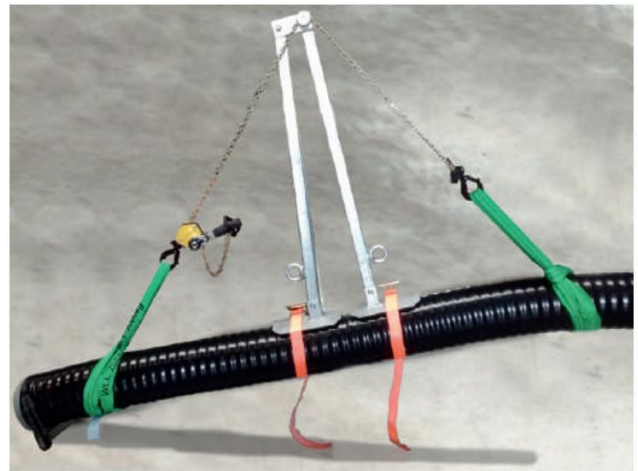

V2 SECOND WAY:

The pipe end is bent downwards.

Place the closed pipe straightener on the curved pipe. (Distance between the two base plates should be about 2 fingers wide!)

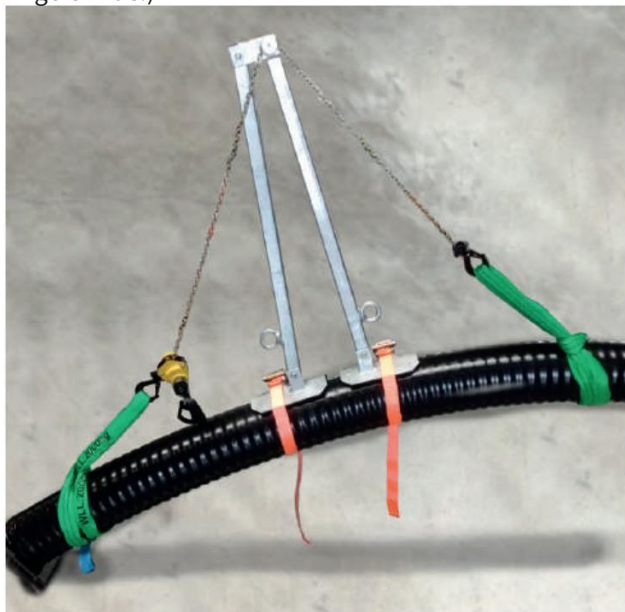

Hook the chain hoist into a round sling, chain lead over the upper bolt of the laying aid and hang the chain hoist in the second-round sling.

Tighten the chain hoist using the ratchet. Clamp until the pipe is straight.

V3 THIRD WAY:

The use of pipe straightener to pull the pipes.

Attach the pipe straightener to the pipe as described in the first way.

Hook the chain hoist to the towing eye of the pipe straightener. Now the pipe can be moved with the help of the chain hoist.

With a second pipe straightener, 2 pipe ends can be pulled together.

SLEEVE SYSTEM

HeatClick

The HeatClick sleeve system guarantees the highest construction site quality without time-consuming gluing, screwing or shrinking with a secure connection technology and the best thermal insulation properties.

The **HeatClick** sleeve system from **RK Infra** inspires thanks to the quick and easy installation and an innovative molding part system,

The stable click system has one big advantage: even heavily bent pipes can be connected easily with the **HeatClick** sleeves even despite the weather. This is because unnecessary gluing, screwing and shrinking is no longer necessary.

EASY INSTALLATION

Guide bars facilitate the positioning of the half shells which only have to be clicked together and locked in the final shape. An already installed sea guarantees a safe and permanent water resistance.

Between the **HeatClick** sleeve and the **FibreFlex/HeatFlex** heat pipe, the sealing rings are pushed and reliably held by two locking rings. After the green plug-in clips are attached, the PU foam can be directly filled in directly without waiting time.



Position the sub-sleeve molded part under the sliding sleeve molding.



Position the sleeve and leave the longer clips on the side (see marking).



After all clips snap into place, attach the rubber sleeve seals onto the sleeve and pull it over the sleeve.

Warning: Clean the sealing surfaces on the sockets before fitting.



SAFETY & HEAT INSULATION

This safe connection technology offers the highest heat insulation qualities through the use of polyurethan foam.

The sealing rings are optimally matched to the pipe geometry, allowing for a high degree of flexibility when it comes to the movement of the pipe and seals the pipe and the sleeve reliably.

FLEXIBLE CONNECTION

Thanks to its flexible adjustment, the small sleeve covers an outer pipe diameter of 76mm to 142mm. the big sleeve is used for pipe outside diameters up to 202mm.

The **HeatClick** sleeves are available in the versions of **I-**, **L-** and **T-Sleeves** in both sizes.

This connection technology is safe, durable and universally applicable.

PROS:

- > Safe and efficient heat insulation
- > Quick and tool-free assembly without gluing, screwing and shrinking
- > Ribbing on the outside of the sleeve provides high statistical charges
- > Stress-free assembly due to its flexible sealing ring system made of EPDM
- > Injection molded parts from high quality ABS plastic



Use the rubber sleeve seal to the half shells of the locking rings to seal the rubber socket onto the sleeve.



Prepare the PU foam according to operating instructions and put it in the sleeve. Fill the sleeve at the deepest point.

⚠ warning: wear closed clothing, work gloves and safety goggles when preparing the foam.



Finished **HeatClick** sleeve!

HOUSE ENTRY

Labyrinth seal

The labyrinth seal is used to seal the pipe entries in masonry with non-pressing water.

There is a possibility to use the labyrinth seal in wall openings as well as in the core hole drilling.

The FibreFlex/HeatFlex are generally brought in for house entries. If this is not possible, the curvature in the area of the building entry should not be less than 2,5 times the minimum bending radius of the FibreFlex/HeatFlex pipes given in the Table 49 in order to avoid pipe stresses in the area of the wall penetration.

When the space is too tight, there is an option to fall back on the prefabricated RK Infra house entry bends or on HeatClick L-sleeves.

WALL BREAKTHROUGH

Dimensions and distances (location) heat conduction.

So that a wall breakthrough can be backfilled professionally with commercially-available expanding mortar, there must be a distance of approx. 80mm between the pipe's outer jacket and masonry.

The dimensions resulting from this requirement for breakthroughs can be found in Table 51 for RK Infra UNO pipes and in Table 52 for RK Infra DUO pipes.

FibreFlex/HeatFlex Outer diameter	Minimum bending radius
76 mm	0,70 m
91 mm	0,90 m
111 mm	0,90 m
126 mm	1,00 m
142 mm	1,10 m
162 mm	1,20 m
182 mm	1,30 m
202 mm	1,40 m
225 mm	1,60 m

Tab. 49: Minimum bending radii FibreFlex/HeatFlex



Abb. 35: Labyrinth seal

FibreFlex/HeatFlex Jacket pipe D_a	Labyrinth seal D_{aL}	Article No.
76 mm ^M	118 mm	100.400.132
91 mm	133 mm	100.400.142
111 mm	153 mm	100.400.152
126 mm	168 mm	100.400.162
142 mm	183 mm	100.400.173
162 mm	203 mm	100.400.192
182 mm	223 mm	100.400.212
202 mm	234 mm	100.400.222
225 mm	261 mm	100.400.223
250 mm	286 mm	100.400.232

Tab. 50: Labyrinth seal and accessories FibreFlex/HeatFlex-Rohr

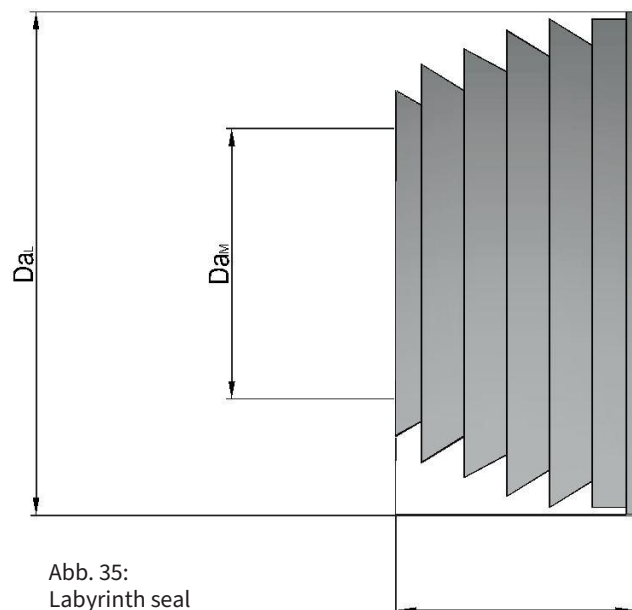

Abb. 36: Wall breach **FibreFlex/HeatFlex-Rohr UNO**

Outer diameter Jacket pipe Da	Wall breach for 2 pipes ca. H x L
76 mm	225 mm x 400 mm
91 mm	250 mm x 450 mm
111 mm	275 mm x 500 mm
126 mm	300 mm x 550 mm
142 mm	325 mm x 600 mm
162 mm	325 mm x 600 mm
175 mm	350 mm x 650 mm
182 mm	350 mm x 650 mm
202 mm	375 mm x 700 mm
250 mm	400 mm x 750 mm

Tab. 51: measurements wall breach **FibreFlex/HeatFlex UNO**

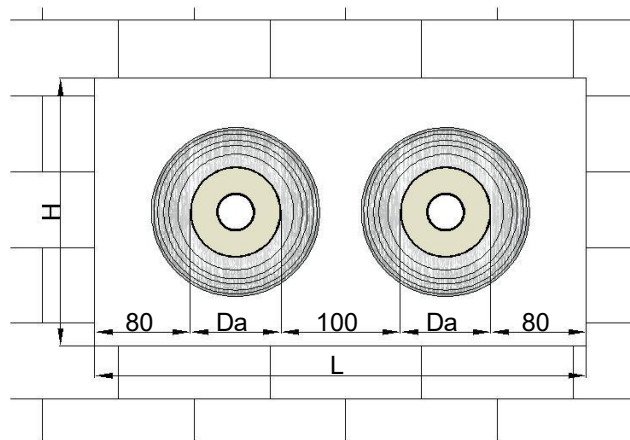

Abb. 37: Wall breach **FibreFlex/HeatFlex DUO**

Outer diameter Jacket pipe Da	Wall breach for 1 pipe ca. H x L
76 mm	225 mm x 225 mm
91 mm	250 mm x 250 mm
111 mm	275 mm x 275 mm
126 mm	300 mm x 300 mm
142 mm	325 mm x 325 mm
162 mm	325 mm x 325 mm
175 mm	350 mm x 350 mm
182 mm	350 mm x 350 mm
202 mm	375 mm x 375 mm
250 mm	400 mm x 400 mm

Tab. 52: measurements wall breach **FibreFlex/HeatFlex DUO**

HOUSE ENTRY

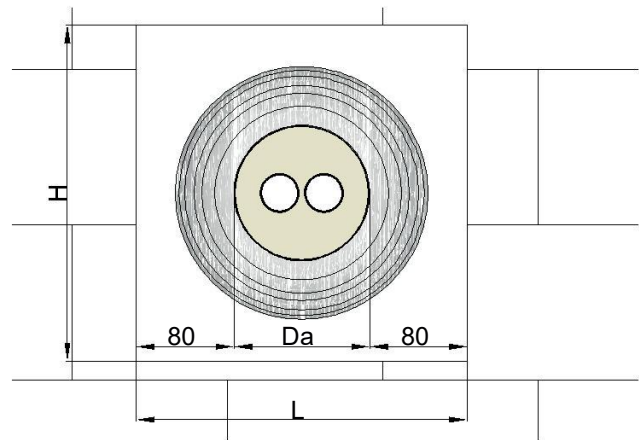
Wall sealing labyrinth ring

CORE HOLE

A distance of approx. 80mm must be maintained between the outer jacket of the pipe and the wall of the core hole so that professional backfilling with commercially available expanding mortar can be carried out when core holes are drilled.

The diameter for the core hole resulting from this requirement is shown in Table 53. Furthermore, make sure that the distance between 2 core holes is at least 30mm.



Abb. 38: Core hole FibreFlex/HeatFlex UNO



Abb. 39: Core hole FibreFlex/HeatFlex DUO

Outside diam. Jacket pipe Da	Min. diameter Core hole d
76mm-111mm	250mm
120mm-150mm	300mm
162mm-190mm	350mm
202mm-250mm	400mm

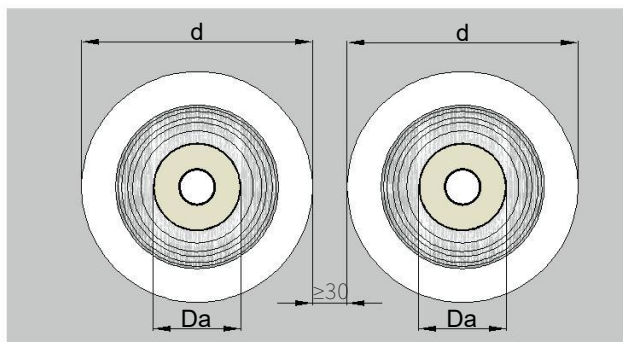
Tab. 53: Diameter core hole
FibreFlex/HeatFlex UNO und DUO

ASSEMBLY OF THE WALL SEALING LABYRINTH RING

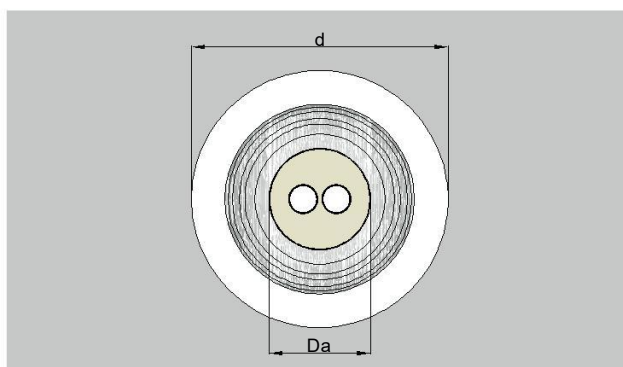
The labyrinth seal is installed according to Fig. 39 and attached to the FibreFlex/ HeatFlex pipe. This way, the smooth side of the sealing ring is turned towards the buildings inside and the sloping side is turned to the outside of the wall.

The distance between the labyrinth seal and the outside wall should be approx. 80mm.

The gap is filled with commercially available expanding mortar.



Abb. 40: section of wall duct

In detail, the following work steps are necessary for the introduction of the FibreFlex/HeatFlex-pipes into the wall duct:

- > Cut the pipe length so that the overhand in the building is sufficient for further installation.
- > Clean the pipe in the area of the wall duct.
- > At the end of the pipe, place the labyrinth seal diagonally with the stepped side first and the labyrinth seal over the end and pull it over the pipe.
- > Now slide the labyrinth seal evenly over the pipe without tilting.
- > The labyrinth seal is properly sealed once it is perpendicular to the pipe's axis.
- > After positioning the labyrinth seal, the pipe is pushed through the wall duct.

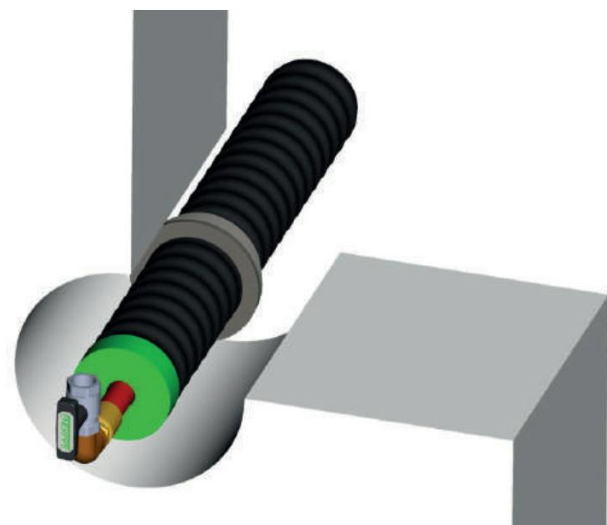

Abb. 41: assembly recommendation labyrinth seal

- > Note that the horizontal distance from the labyrinth seal to the outside of the wall should be approx. 80mm.
- > Then seal the pipe penetration through an all-round backfilling with commercially available mortar.
- > Apply a thick coating to the outer wall surface in the area of the wall opening or the core hole for additional seating.

House entry

Sealing ring NDW30 and DW60

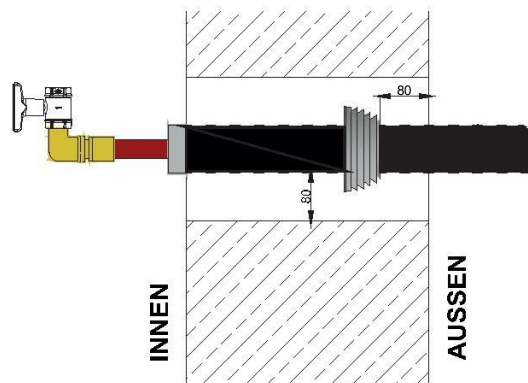
The RK Infra ring seal is suitable for sealing FibreFlex/ HeatFlex pipes as part of a wall duct. The sealing is carried out in core holes (concrete), pipe sleeves or wall sleeves made out of plastic (concrete/ masonry).

Due to its special 2-component structure, the RK Infra sealing sleeve is particularly suitable for the sealing of the **RK Infra** pipes. The sealing for the wall or the casing is done with a black solid rubber made of medium hardness EPDM. Toward the pipe, however, the seal softens over a green Duroplast elastomer with easy function, which enables assembly without a torque wrench. For the simple parallel routing of a data line, the **RK Infra** sealing sleeve has 3 as standard holes (13mm) for pipe diameters of 7-14mm.

It should be noted that when installing a core hole, the inside of the core hole should be sealed with epoxy resin before the sealing sleeve is introduced.

The **RK Infra wall penetration** sealing sleeve is used exclusively for sealing **FibreFlex/ HeatFlex** pipes and is not intended as a fixed point. The structural design of the sealing sleeve allows a slight axial movement of the district heating pipe.

The field of application extends from non-pressing to pressing water.



Abb. 42: Ring seals

INSTALLATION INSTRUCTIONS AND DIMENSIONS CORE HOLE/ FEED TUBE WALL/ WALL SLEEVES

The distance between two core holes or casings is at least 30 mm. the pre-insulated pipe must be centered and supported. After the installation, the borehole may deviate from the axis of the borehole by a maximum of 7°-8°.

The core holes should be filled with **RK Infra** epoxy on the whole length before installing the sealing sleeve in order to close the fine cracks and blowholes and protect the concrete and the rebar.



Abb. 43 Distance between 2 core drill holes or liners

With the help of tables 54 and 55, we can find the necessary drilling size for individual FibreFlex/ HeatFlex pipes.

RING SEAL DW60

Outer diameter Pipe Da	Min. diameter core drill holes d	Article Number
76 mm	150 mm ±2	977000150076
91 mm	200 mm ±2	977000200091
111 mm	200 mm ±2	977000200111
126 mm	200 mm ±2	977000200126
142 mm	200 mm ±2	977000200142
162 mm	250 mm ±2	977000250162
182 mm	250 mm ±2	977000250182
202 mm	300 mm ±2	977000250202
225 mm	300 mm ±2	977000300225
250 mm	350 mm ±2	977000350250

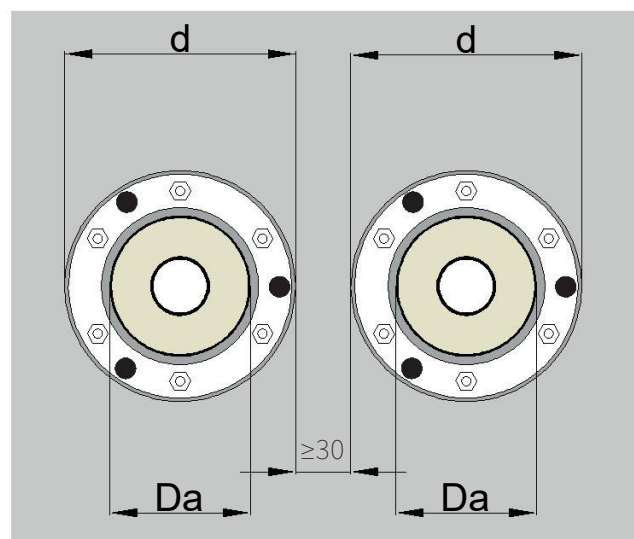
Tab. 54: core drill holes diameters

The use of the sealing sleeve ring seal DW60 takes place with pressurizing water.



Abb. 44: Ring seal DW60

The wall seal should be pushed towards the outer wall until it is bound with it. It is important to take care that the wall seal does not ever go beyond the outer wall.

To stabilize, secure the position and center the FibreFlex/ HeatFlex pipe in the core hole, and install an additional annular seal NDW30 for wall thickness if necessary.

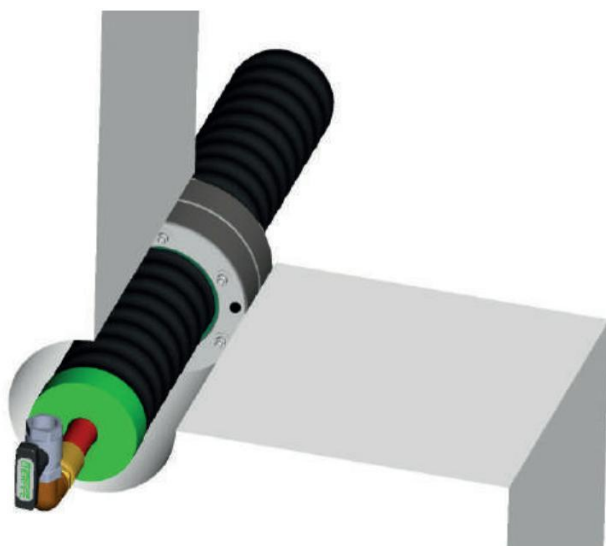

Abb. 45: Ring seals DW60 and NDW30 at wall thickness ≥ 25 cm

RING SEAL NDW30

Outer diameter pipe Da	Min. diameter Core drill holes d	Article Number
76mm	150mm±2	979000150076
91mm	200mm±2	979000200091
111mm	200mm±2	979000200111
126mm	200mm±2	979000200126
142mm	200mm±2	979000200142
162mm	250mm±2	979000250162
182mm	250mm±2	979000250182
202mm	300mm±2	979000300202
225mm	300mm±2	979000300225
250mm	350mm±2	979000350250

Tab. 55: core drill holes diameters

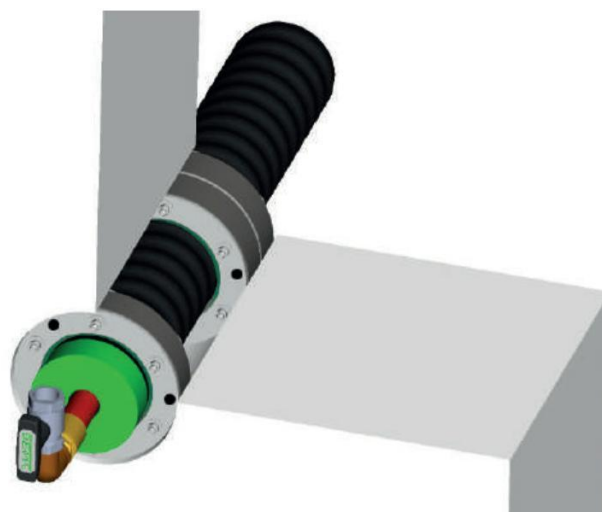
HOUSE ENTRY

Wall penetration sealing sleeve HeatSEAL NDW30 and DW60

The installation of the ring seal **NDW30** is recommended for non-pressurizing water.



Abb. 46: Ring seal **NDW30**

The seal should be pushed towards the outer wall until it is bound with it. Make sure that the seal does not protrude beyond the outer wall. To stabilize, secure the position and centering pipe in the core hole. If the wall thickness is or more than 25cm, the annular space seal NDW30 can also be installed.

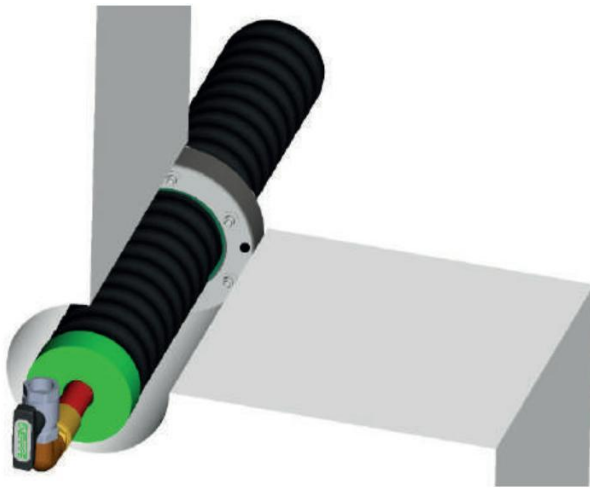

Abb. 47: Ring seal **NDW30**,
twice installed at wall thickness ≥ 25 cm

Please make sure that the ring seals **DW60** and **NDW30** for all aforementioned installation types all point the nuts to the inside of the building so that they can be retightened at any point of time.

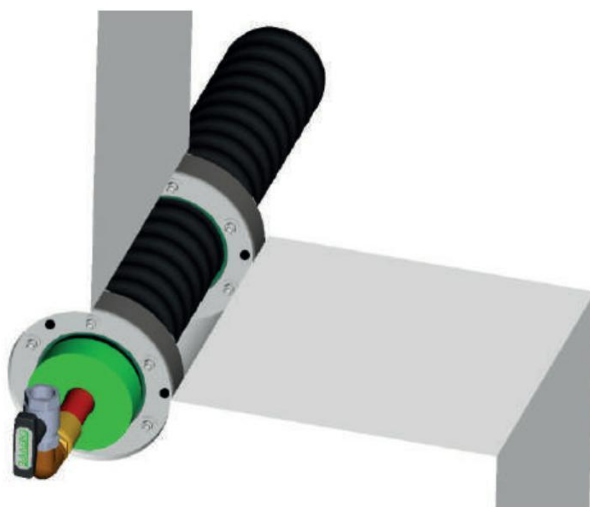

Abb. 48:
Ring seal **DW60** and **NDW30** installed

WALL SLEEVE

The subsequent production of core holes can be avoided if the shell construction phase has an accordingly-sized wall sleeve which is installed. The wall sleeve can also be installed in a subsequently made wall breakthrough. However, it should be noted that the wall sleeve with swelling and waterproof mortar should be embedded with it.

For the installation of the press seal

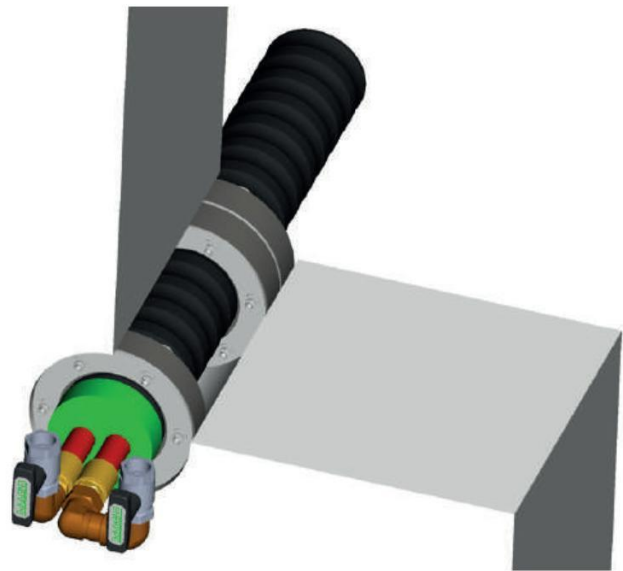

Wall sleeve Inner diameter	Wall sleeve Length	Article No.
100 mm	400 mm	978000106100
125 mm	400 mm	97800013125
150 mm	400 mm	978000158150
200 mm	400 mm	978000210200
250 mm	400 mm	978000280250

Tab. 56: Wall sleeve

NDW30 and DW60 in the wall sleeves apply for the same conditions as for the installation in the core hole.

INSTALLATION RING SEAL

The following steps are to be followed in the installation:

- ✓ Roll out the pipe.
- ✓ Clean the pipe.
- ✓ Inner wall of core drilling/ casing/ protective tube in the installation area should be cleaned.
- ✓ Check the medium pipe for centric fixation.
- ✓ Do not assume any storage function for the press ring seal inserts and use them exclusively for pressure-tight, elastic sealing of lines and cables. Slight axial movements of the medium pipe are allowed.
- ✓ The inner wall of core drilling can be sealed with epoxy before installing the sealing insert.
- It is important to ensure that the sealing insert (muff inside) is installed from the side of the building which is easily accessible even after the completion of the project.
- ✓ Slide the sealing insert over the medium pipe – do not dismantle – and completely slide it into the annular space.
- Tighten all the screws crosswise in several steps clockwise with the same number of turns in several stages until the sealing insert fills the annular space or it is in contact with the inner and outer wall.
- ✓ Tighten all the screws evenly several times in a clockwise or an anti-clockwise direction until the green elastomeric material fills the gap between the pressure flange and the medium pipe.



Notice: The purchaser of the annular space **sealing rings** bears the responsibility for the suitability for use of the products and for all damages and consequential damages caused by improper installation.

HOUSE ENTRY

RK Infra home entry bends

RK Infra house entry bends are used where the possible bending radius for house entry is smaller than 2,5 times the minimum bending radius specified in table 57.

Usually, it is the case that the building should be connected if it does not have a basement. The **RK Infra** house entry bends are generally produced at lengths 1,10 x 1,60 m (DN 20 – DN 125 medium pipe PE-Xa) bzw. 1,00 x 1,00 m (DN 150 medium pipe steel).

Please note that the pipe end caps need to remain attached to the medium pipes until assembly to avoid contamination.

FibreFlex/HeatFlex Outer diameter	Minimum Bending radius
76 mm	0,70 m
91 mm	0,90 m
111 mm	0,90 m
126 mm	1,00 m
142 mm	1,10 m
162 mm	1,20 m
182 mm	1,30 m
202 mm	1,40 m
225 mm	1,60 m

Tab. 57: Minimum bending radii FibreFlex/HeatFlex

Before the setting up of the floor plates, one or two **RK Infra** entry bends are provided at the place in the formwork of the floor plate.

In the case of existing strip foundations, a corresponding recess for the **RK Infra** building entry bend must be provided.

For the forward and return flow of the **FibreFlex/HeatFlex** UNO pipe, a corresponding **RK Infra** house entry bend is required.

For DUO pipes there is an according **RK Infra** house entry bend available.



Abb. 49: Measurements house entry bend DN 20 – DN 125 (mm)



Abb. 50: house entry bends UNO pipe/DUO pipe

ASSEMBLY

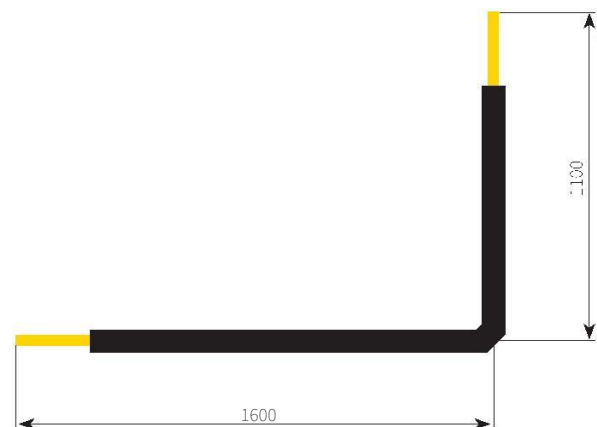
For the assembly of the **RK Infra** house entry bends is the following important to note:

- > The house connection should be in the immediate vicinity of the outer wall.
- > The distance between the middle of the medium pipe and the wall should be ca. 0,15 to 0,2 m.
- > Push the labyrinth seal onto the cleaned **RK Infra** house entry bend and position it so that it lies within the floor slab.
- > The vertical leg of the **RK Infra** house entry bend should be put in place in the formwork of the floor plates in a way that the concrete floor plates remain in their original position.
- > When assembling the **RK Infra** house entry bends, a non-positive connection is required on site to pay attention to the bottom plate.
- > The height of the **RK Infra** house entry bend should be installed in such a way that it protrudes over the floor plate and over the top of the finished floor (OK FFB). The insulation of the medium pipe must be at least 4 cm thick so that the **RK Infra** PE end cap can still be installed to protect the front insulation over the top edge of the finished floor (OK FFB) in the connection space.



Abb. 51: House entry bend DN 150 (mm)



Abb. 52: assembly example house entry bend

HOUSE ENTRY

RK Infra empty pipe bends

The RK Infra empty pipe bend is used in preparation for the house connections used in a single-story building. With this it is optional to insert the HeatFlex/ FibreFlex pipe during house connection work. The insertion of data and fiber optic cables is also possible with the use of the RK Infra empty pipe bend. Reliable sealing is provided by the annular space seal with an integrated data cable or a fiberglass conduit seal.

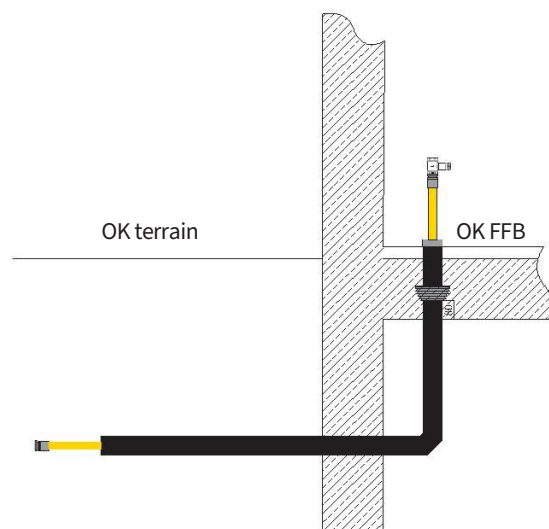
RK Infra supplies the empty pipe bend in height alternatives of 1,5m and 2m from the bottom of the trench to the finished floor of the connected room. In order to be able to mount the RK Infra empty pipe bend, the position of the building entry must be specified with a scaffolding. The procedure is shown in the sample calculations section.

Advantages:

- Pressure tight to 1bar
- Radon tight
- lower assembly effort
- no additional connection points



Abb. 54 RK Infra empty pipe bend example



Abb. 55 RK Infra empty pipe bend mass

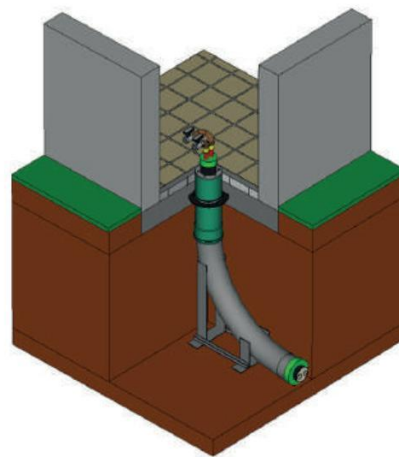

Abb. 56 RK Infra empty pipe bend with on-site extension

Laying with an example calculation

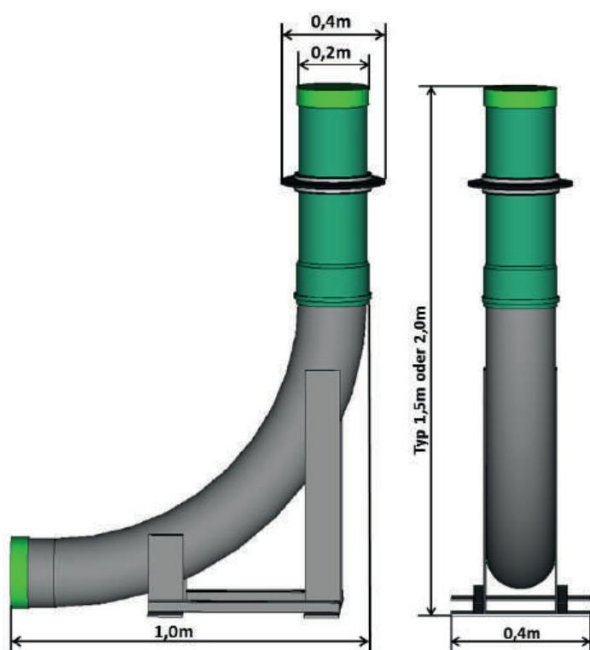

Legende:

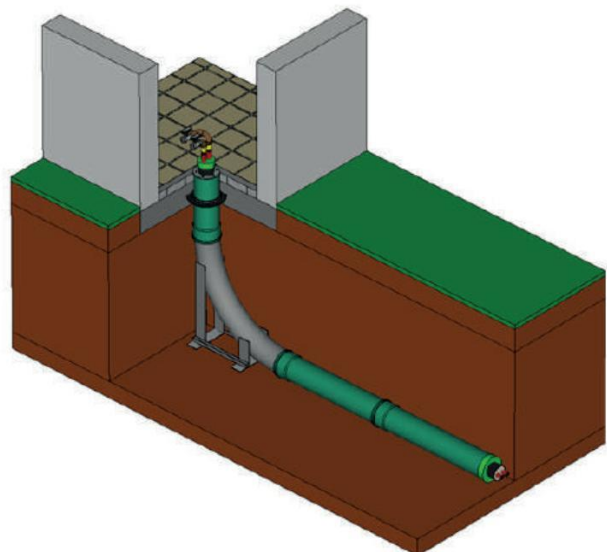
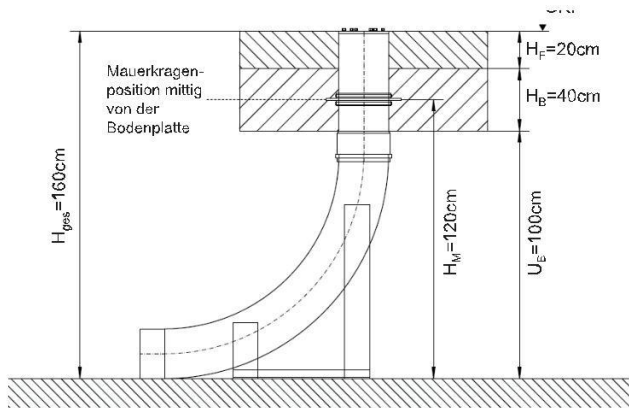
U_B: Unterkante Bodenplatte

H_F: Höhe Fertigfußboden

H_{ges}: Gesamthöhe

H_B: Höhe Bodenplatte

H_M: Höhe Mauerkragen

OKF: Oberkante Fußboden

Selection of building entry type

U_B: 100cm H_B: 40cm H_F: 20cm H_{ges}: ?

$$H_{ges} = U_B + H_B + H_F = 100\text{cm} + 40\text{cm} + 20\text{cm}$$

Result: H_{ges} = 160cm

Choice:

H_{ges} ≤ 150cm > Typ 1,5

H_{ges} > 150cm > Typ 2,0

Calculation of the height of the wall collar

U_B: 100cm H_B: 40cm H_M: ?

$$H_M = U_B + \frac{(H_B)}{2} = 100\text{cm} + \frac{(40\text{cm})}{2}$$

Result: H_M = 120cm

The empty pipe set includes:



Empty pipe bend DN200

With a preassembled standup device
In a 90° angle
(Radius 0,8 m)



Passage floor plate

pipe DN200
length: 0,5 m
or 1 m



Wall collar for DN 200 pipe

With tightening-straps up to 50 mWS pressure tightness



Ring seals



Sealing caps



accessory

extension pipe
DN200 2m incl. sleeve
(not in the set)

CHECKLIST

Material for house connection

Connection UNO



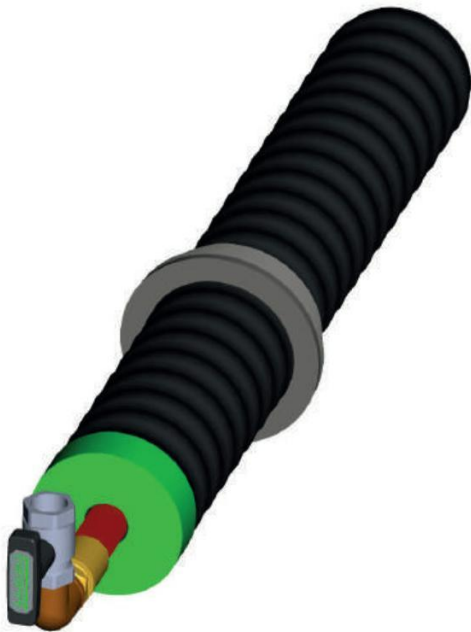



- > Wall breakthrough single pipe
- > Non-pressurizing water









Connection DUO

- > Wall breakthrough double pipe
- > Non-pressurizing water



Product	Number	Pictured
Wall sealing labyrinth ring	2	
PE end cap	2	
Compression fitting with outside thread	2	
Compression sleeve	2	
Ball valve with inside and outside thread	2	
Bend 90° with inside and outside thread	2	

Product	Number	Pictured
Wall sealing labyrinth ring	1	
PE end cap	1	
Compression fitting with outside thread	2	
Compression sleeve	2	
Ball valve with inside and outside thread	2	
Bend 90° with inside and outside thread	3	

Connection UNO

- > Wall breakthrough with single feed pipe
- > Non-pressurizing water



Connection DUO

- > Wall breakthrough with double feed pipe
- > Non-pressurizing water



Product	Number	Pictured
coating pipe	2	
Wall penetration sleeve CaldoSEAL NDW30	2	
optional at wall thickness > 25 cm	4	
PE end cap	2	
Compression fitting with outside thread	2	
Compression sleeve	2	
Ball valve with inside thread	2	
Bend 90° with inside-outside thread	2	

Product	Number	Pictured
coating pipe	1	
Wall penetration sleeve CaldoSEAL NDW30	1	
optional at wall thickness > 25 cm	2	
PE end cap	1	
Compression fitting with outside thread	2	
Compression sleeve	2	
Ball valve with inside thread	2	
Bend 90° with inside-outside thread	3	

CHECKLIST

Material for house connection

CONNECTION UNO

- > Core drilling for wall penetration sleeve CaldoSEAL
- > NDW30
- > Non-pressurizing pipe



CONNECTION DUO

- > Core drilling for wall penetration sleeve CaldoSEAL
- > NDW30
- > Non-pressurizing pipe



Product	Number	Pictured
Epoxy resin	1	
Wall penetration seal NDW30	2	
optional at wall thickness > 25 cm	4	
PE end cap	2	
Compression fitting with outside thread	2	
Compression sleeve	2	
Ball valve with inside thread	2	
Bend 90° with inside-outside thread	2	

Product	Number	Pictured
Epoxy resin	1	
Wall penetration seal NDW30	1	
optional at wall thickness > 25 cm	2	
PE end cap	1	
Compression fitting with outside thread	2	
Compression sleeve	2	
Ball valve with inside thread	2	
Bend 90° with inside-outside thread	3	

CONNECTION UNO

- > Core drilling for sealing ring DW60
- > Single pipe
- > pressurizing water



CONNECTION DUO

- > Core drilling for sealing ring DW60
- > Double pipe
- > pressurizing water



Product	Number	Pictured
Epoxy resin	1	
Ring seal DW60	2	
optional at wall thickness > 25 cm ring seal NDW30	2	
PE end cap	2	
Compression fitting with outside thread	2	
Compression sleeve	2	
Ball valve with inside thread	2	
Bend 90° with inside-outside thread	2	

Product	Number	Pictured
Epoxy resin	1	
Ring seal DW60	1	
optional at wall thickness > 25 cm ring seal NDW30	1	
PE end cap	1	
Compression fitting with outside thread	2	
Compression sleeve	2	
Ball valve with inside thread	2	
Bend 90° with inside-outside thread	3	

PRESSURE AND TIGHTNESS

FibreFlex and HeatFlex

PRESSURE AND LEAK TEST

RK Infra FibreFlex and HeatFlex

Basis for pressure test

According to DIN EN 806-4 and DIN 1988, the pipes that have been completed but not yet covered must be checked before they are put into operation through a pressure test. The tightness of the system can only be checked by visual inspection of uncovered connection points.

Note: the finest leaks can only be detected with a visual inspection. Water leakage can be located at a high pressure. A subdivision of the heating network into smaller test sections increases the test accuracy.

A reliable pressure test must be carried out with water. An air test is not carried out for safety reasons and not recommended due to a lack of control options.

Process of a pressure test:

1. It must be ensured that all building connections suitable for ball valves are tightly closed. All system parts located in the route must be checked for pressure suitability and tightness. A pressure gauge with the quality class 1 with an accuracy of 0,1 bar should be used.
2. Fill the water from the lowest point and gradually empty the lines to the higher pipe section. This process can be used at the same time to flush out dirt from the route sections. The water temperature should not differ more than 10K from the material temperature.
3. Start the **pressure test part 1** with 1,1-times operating pressure. Example: FibreFLEX 10 bar (at 80°C) x 1,1 = 11 bar test pressure. Maintain this pressure for 30 minutes and pump again and again if necessary. During this time, check all connecting parts for leaks.
4. After 30 minutes, if the system seems tight, the test pressure is reduced by half. Example 11 bar x 0,5=5,5 bar. The **pressure test part 2** must last for another 120 minutes. However, it is not allowed to repress during this period.
5. The route section is considered tight if the test pressure has not fallen and all connections are tight. If the pressure has dropped, the process must be repeated from point 4.
6. After a successful pressure test, the data is archived and noted down.



Abb. 57:
Diagram
Course of the
Pressure test

PRESSURE TEST REPORT

For RK Infra local heating installations based on DIN EN 806-4 o ZVSHK leaflet

Test medium: water

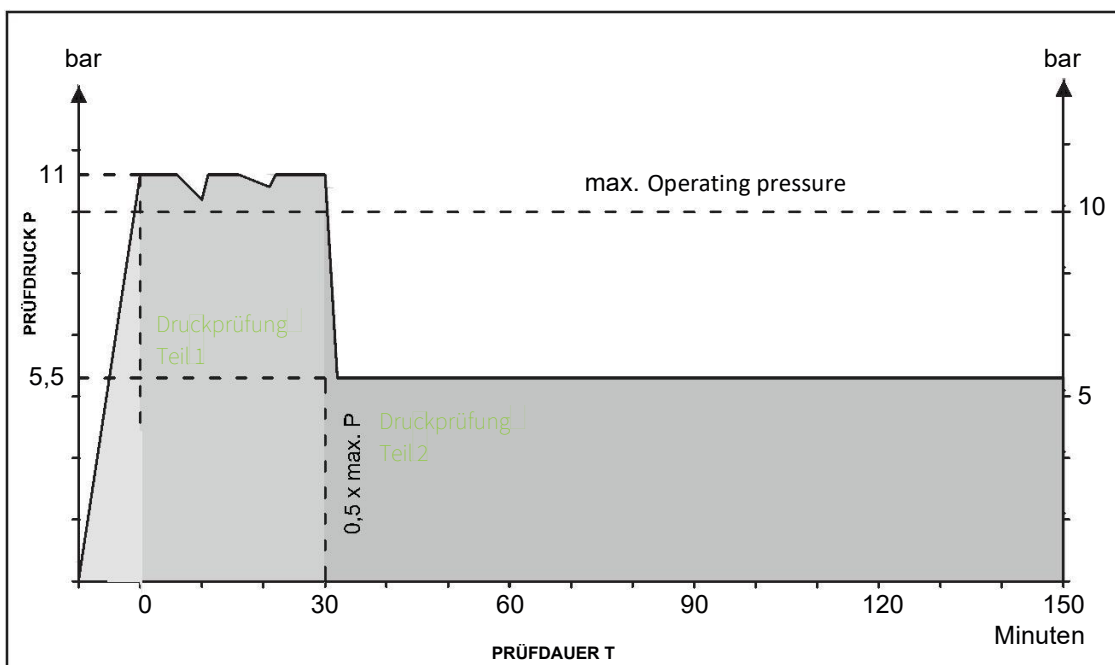
Note: the explanations and technical information in the current technical documents from RK Infra must be observed!

Construction _____
 project: _____

Construction stage: _____

Examining person/ _____
 company: _____

All containers, devices, and fittings, e.g. safety valves and expansion tanks, which are not suitable for the pressure test must be disconnected from the system during the pressure test.

Pressure test

Part 1:

Test pressure: _____ bar (1,5 times the max. operating pressure)

Pressure time: 30 min

During the test period, there are pressure differences due to cooling processes caused by refilling. They are balanced through refilling of suitable water.

Visible parts of the system must be subjected to a visual inspection.

Plant parts are optically sealed

End goal: test pressure stays constant during the time period of 30 min.

Operating pressure stays constant

Part 3:

Test pressure: _____ bar (0,5 times the initial test pressure from the pressure test part 1)

Pressure time: 120 min

Pressure in the piping system is constant:

Piping system is tight:

Confirmation of the system tightness

 Place/ Date

 Signature contractor

 Place/ Date

 Signature client

SURVEY FORM

House connection

House connection questionnaire for planning a heating network

in: _____

First and last name _____

Street, house number, place _____

Phone, E-Mail _____

Building data One family house Semi-detached house Terraced house
 Apartment building with _____ WE _____
 Year of construction _____ Extension _____
 Area _____ m² of which approx. heated _____%

Underfloor/ wall heating Radiator Air heater

Electric heating _____

No. of residents _____ No. Of baths _____

Additional notices: _____

z.B.: Dämmstandard, Erweiterungspläne, sonstiger Wärmebedarf (Pool, Garage, ...)

	Type	Performance	Construction year	Brennwert	Fuel per year ⁺
Zentralheizung	Oil heating	kW			Ltr.
	Log heating	kW			Ster
	...	kW			
	...	kW			
Einzelofen	Fireplace (wood)	kW			Ster
	...	kW			

*im Durchschnitt der letzten 3 bis 5 Jahre

Addition for wood heating: proportion of _____% , softwood _____%
 hardwood _____%

Solar system _____ m² for service water Heating support

Hot water tank (Boiler) Volume: _____ Liter, year of construction: _____

Heating buffer tank number: _____ piece total vol.: _____ Liter, year of construction: _____

There is no replacement obligation according to § 72 of the Building Energy Act

I consent to RK Infra GesmbH to use my address data internally for the purpose of order processing.
 (DSGVO Article 6 Abs. 1, lit. a)

I consent to RK Infra GesmbH to use my data internally for the purpose of advertising and to inform me over innovations. (DSGVO Artikel 6 Abs. 1, lit. a)

-I can revoke this consent at any time without giving reasons-

You can find out which data we process according to Article 13 and 14 GDPR on our home page at <https://www.RKInfra.com/datenschutzerklarung/>.

With the confirmation of the data, no contractual obligations arise for the heat consumer. We assure you that your data will only be used for the planning of your project and not be passed onto a third party.

Confirmation of the data by the heat consumer: _____

Law on saving energy and using renewable energies for heating and cooling in buildings (Building Energy Saving Act – GEG).

§ 72 Operating ban for boilers and oil heaters

(1) Building owners are allowed to have their boilers which use liquid or gaseous fuel if installed or erected before January 1, 1991.

(2) building owners are allowed to have their boilers which use liquid or gaseous fuel if installed or erected before January 1, 1991, but after 30 years from the date of installation, they should not be operative.

(3) Paragraphs 1 and 2 do not apply to:

- a. low temperature boilers and condensing boilers, as well as
- b. heating systems with a nominal output of less than 4 kilowatts or more than 400 kilowatts.

§ 73 Exceptions

(1) in the case of a building with no more than 2 apartments, of which the owner lives in the apartment on or before February 1st, 2002, the obligations according to § 71 und § 72 paragraphs 1 und 2 are only to be fulfilled by the new owner in the event of a change of ownership after February 1st, 2002.

(2) the deadline for fulfilling the obligation is two years from the first transfer of ownership after February 1st, 2002.

NORMS AND REGULATIONS

In addition to the installation and operation of heating system, there are several applicable local, national and international laws and regulations to note about the heating system. These are German (DIN), European (EN) or international (ISO) standards, regulations and guidelines from various associations such as the B. DVGW, AGFW, VDE, VDI and others. Furthermore, the relevant provisions of the professional associations and the regulations of the local utility companies must be considered.

In order to give you a brief overview, we have listed important regulations for the areas of general (pipe materials), planning, laying and commissioning on the following pages. The list shows the most important regulations but does not claim to be complete. Please remember that the standards, regulations and guidelines you use are always up to date.

General

AGFW FW 420 part 1

district heating lines/ networks from flexible pipe systems, systems from polymer medium pipes (PMR).

DIN EN ISO 3386

Polymeric materials, flexible foams – determination of compressive stress-strain properties

ASTM C 1113 / C 1113M

Testing the thermal conductivity of refractory materials using hot wire (platinum resistance thermal method).

Recommendation of the Federal Environment Agency (UBA) guideline for hygienic assessment of organic materials in contact with drinking water (KTW guideline).

DIN EN 253

District heating pipes – factory insulated composite jackets pipe systems for district underground heating networks

DIN EN 15632

District heating pipes – factory insulated flexible pipe systems

DIN 2425 part 2

Planning works for the supply industry, water management and for long-distance pipelines

DIN EN ISO 13760

Plastic pipes for the transport of fluids under pressure – Miner's rule – calculation method for cumulative damage

DIN 4102

Fire behavior of the building materials and components

DIN EN ISO 15875

Plastic piping systems for hot and cold water installations – cross-linked polyethylene (PE-X)

DIN 4726

Warm water surface heating and radiator connection – plastic pipe and composite pipe systems

DVGW worksheet GW 332

Squeezing of pipelines made of polyethylene in the gas and water distribution

DIN 16892

Cross-linked high density polyethylene (PE-Xa) pipes – general quality requirements, testing

DVGW worksheet W 270

Multiplication of microorganisms on materials for the drinking water sector – testing and evaluation

DIN 16893

Cross-linked high-density polyethylene (PE-Xa) pipes - dimensions

DVGW worksheet W 400

Technical rules for water distribution systems (TRWW)

DIN 53420

Testing of foams; determination of the bulk density

DVGW worksheet W 531

Manufacture, quality assurance and testing of tubes VPE for the drinking water installation

DIN 53428

Testing of foams; determination of behavior against liquids, vapors, gases and solid substances

DVGW worksheet W 534

Pipe connectors and pipe connections in the drinking water installation

DVGW worksheet W 544
Plastic pipes in the drinking water installation

ISO 1183
Plastics – procedure for determining the density of non-foamed plastics

ISO 11357-3
Plastics – differential scanning calorimetry (DSC) part: determination of the melting and crystallization temperature and the melting and crystallization enthalpy

Planning and laying

AGFW FW 420 part 5
District heating lines from flexible pipe systems – planning, construction and assembly, operation

AGFW W 438
Trenchless pipe installation method for district heating - pipes controllable horizontal directional drilling method – additions and deviations to the DVGW worksheet GW 321

ATV-DVWK-A 127
Static calculation of sewers and pipes

ATV-DWA-A 125
Pipe jacking and related processes

DIN 1055 / DIN EN 1991-1
Effects on structures

DIN EN 1610
Installation and testing of drains and sewers

DIN 4124
Excavations and trenches – embankments, shoring, working space widths

DIN 8074
pipes made of polyethylene (PE) - PE 80, PE 100 - size

DIN 8075
pipes made of polyethylene (PE) - PE 80, PE 100 general information, tests

DIN EN 12831
Heating systems in buildings – methods of calculation the standard heat load

DIN V 4701
Energetic evaluation of heating and ventilation systems

DVGW worksheet GW 304
Pipe jacking and related processes

DVGW GW 315
Instructions for measures to protect and supply systems during construction work

DVGW worksheet GW 321
Controllable horizontal directional drilling methods for gas and water pipes – requirements, quality and assurance

DVGW worksheet GW 324
Milling and plowing methods for gas and water pipes - requirements, quality and assurance

Installation

AGFW Arbeitsblatt FW 510
Requirements for the circulating water of industrial and district heating systems as well as instructions for their operation

DIN 1988
Technical rules for drinking water installation

DIN 18380 (VOB)
VOB procurement and contract regulations for construction work – Part C: general technical contract terms for construction (ATV) – heating systems and central water heating treatment plants

DIN EN 806
Technical rules for the installation of drinking water

DIN EN 1264
Room surfaces and integrated heating and cooling systems with water flow

VDI 2035 sheet 1
Prevention of damage in hot water heating systems

VDI 2035 sheet 2
Prevention of damage in hot water heating systems – waterside corrosion

VDI 4708 sheet 1
Pressurization, venting, degassing

VdTÜV leaflet TECH 1466
Requirements for the circulating water of industrial and district heating systems and instructions for their operation

ZVSHK leaflet
Leak testing of drinking water – installations with compressed air, inert gas or water

LEGAL NOTICES AND SAFETY INFORMATION

Legal notices

Technical information

The technical information for “Local heating pipe technology from **RK Infra**” is valid from September 2023. We point out that the document is protected by copyright and that we reserve all the rights. The dimensions and weights contained in the technical information are guide values. Error and changes excepted.

For your safety and to ensure correct use, make sure to regularly check if the technical information available to you is up to date if you use our products on a regular basis. The date of issuing of the technical information is always printed on the bottom right of the title page.

The current technical information and other technical documents are available directly from **RK Infra** per request. We would like to point out that the areas of application are not recorded in this technical information section. If necessary, make a consultation concerning special applications with the **RK Infra** team.

Norms, regulations and laws

In general, when assembling and installing the pipeline systems, all national regulations are applicable to this area of national and international laying, installation, fall preventions and safety regulations. Read the instructions in the technical information section. Furthermore, the guidelines, applicable laws and standards and regulations of the various institutes and facilities (e.g. DIN, EN, ISO, DVGW, AGFW, VDE and VDI, etc.) are to be considered.

This also applies to corresponding environmental protection regulations, provisions of the professional associations and regulations of the regional and local utility companies.

Make sure to always use the current and up to date status of laws and standards as well as the policies and regulation acts.

The planning and installation instructions are made for the **RK Infra** products. These documents only partially refer to corresponding generally applicable standards or regulations. Further standards, regulations and guidelines that relate to the planning, installation and operation of drinking water or heating systems as well as technical building systems must also be considered, but they are not included in the technical information of this document.

Intended Use

The planning, installation and the operation of the **RK Infra** pipe systems may only be carried out as described in the technical information section and in the assembly instructions for the individual components. Any other way that deviates from these is not intended and therefore not permitted.

If in doubt, contact **RK Infra** directly for detailed advice. Operating and maintenance instructions are also not intended as assembly instructions, only consider the aforementioned. No liability is accepted for improper use or unauthorized changes to the product and any consequences resulting therefrom.

Safety information

Overall

- The top priority is a clean workspace with no unnecessary objects lying around and obstructing construction.
- Adequate lighting at the workplace must be ensured.
- Take appropriate measures to ensure that unauthorized persons have no access to tools and have the assembly space. This is particularly important when working in inhabited areas.
- Wear suitable work clothing.
- Wear protective equipment such as safety shoes, protective helmet and safety goggles.
- There is a risk of loose clothes or jewelry getting stuck in moving parts so it is important to not wear them around the machines.
- The individual components of the respective **RK Infra** system are optimally matched to one another. When using non-system components, it can lead to accidents or other hazards. The same applies to the use of tools that do not belong to the respective **RK Infra** installation system.

Personal

- Use only authorized and trained companies or persons

to install our systems.

- Assembly work or work on electrical systems or line parts may only be carried out by trained and authorized specialist personnel.

Operating and assembly instructions

- Before starting assembly, you must read all the relevant operating and assembly instructions with the relevant safety information fully and carefully. By doing this you make a significant impact concerning the safety of yourself and your peers.
- Refer to the operating instructions and keep them around at the place of installations in order to reference back at it in case of confusion or ambiguities.
- If you are unsure about the installation instructions or the safety information, please contact the technology department of RK Infra directly.
- We point out that the non-compliance with the safety information included can lead to property damage or personal injury.

Assembly

- For the correct use of the **RK Infra** assembly tool, always read and keep in mind the corresponding operating instructions beforehand. The improper use and handling of the tools can lead to personal damage on the one hand, for example severe cuts, bruises or even limb amputation. On the other hand, the improper use can also damage the connection components or cause leaks.
- When cutting the pipe length, keep a sufficiently large safety distance between the cutting tool and the part of the hand which is holding the pipe.
- Due to the sharp blades of the pipe shears, they must be stored and used in a way that does not arise a risk of injury.
- Never stand in the cutting zone of the tool or on moving parts of the tool during the cutting process because you can risk grasping the tool and cutting yourself.
- The flared end of the tube forms after the expanding process back to its original shape (memory effect). Therefore, no foreign object may be introduced into the expanded pipe end during this phase.

During the pressing process, never reach into the pressing zone of the tool or on moving parts.

- As long as the pressing process is not completed, the fitting still may fall out of the pipe and cause injury.
- If the assembly site is changed for maintenance or conversion work, always pull out the mains plug out of the tool and additionally secure it against unintentional switch-on, for safety reasons.

System-specific

- Edges can occur when using insulating sleeves. These must be deburred or removed to prevent injuries.
- Be sure to observe the relevant safety information when processing PUR socket foam (polyol and isocyanate components). Always wear chemical resistant gloves and safety goggles.
- When sawing or sanding down PUR rigid foam, please wear a dust mask.
- PUR sleeve foam develops heat during foaming and heats up the component accordingly.
- If pipes are fixed with tension belts, then there is a risk of squeezing. Reaching into the danger area during the process must be prevented.

Operating parameters

- The operating parameters specified in the technical information must be considered. If the operating parameters are exceeded, an impermissible overload of pipes and connectors can be the result.
- Through the use of appropriate security and control devices (e.g. pressure reducers, safety valves, etc.), compliance with the operating parameters must be ensured.

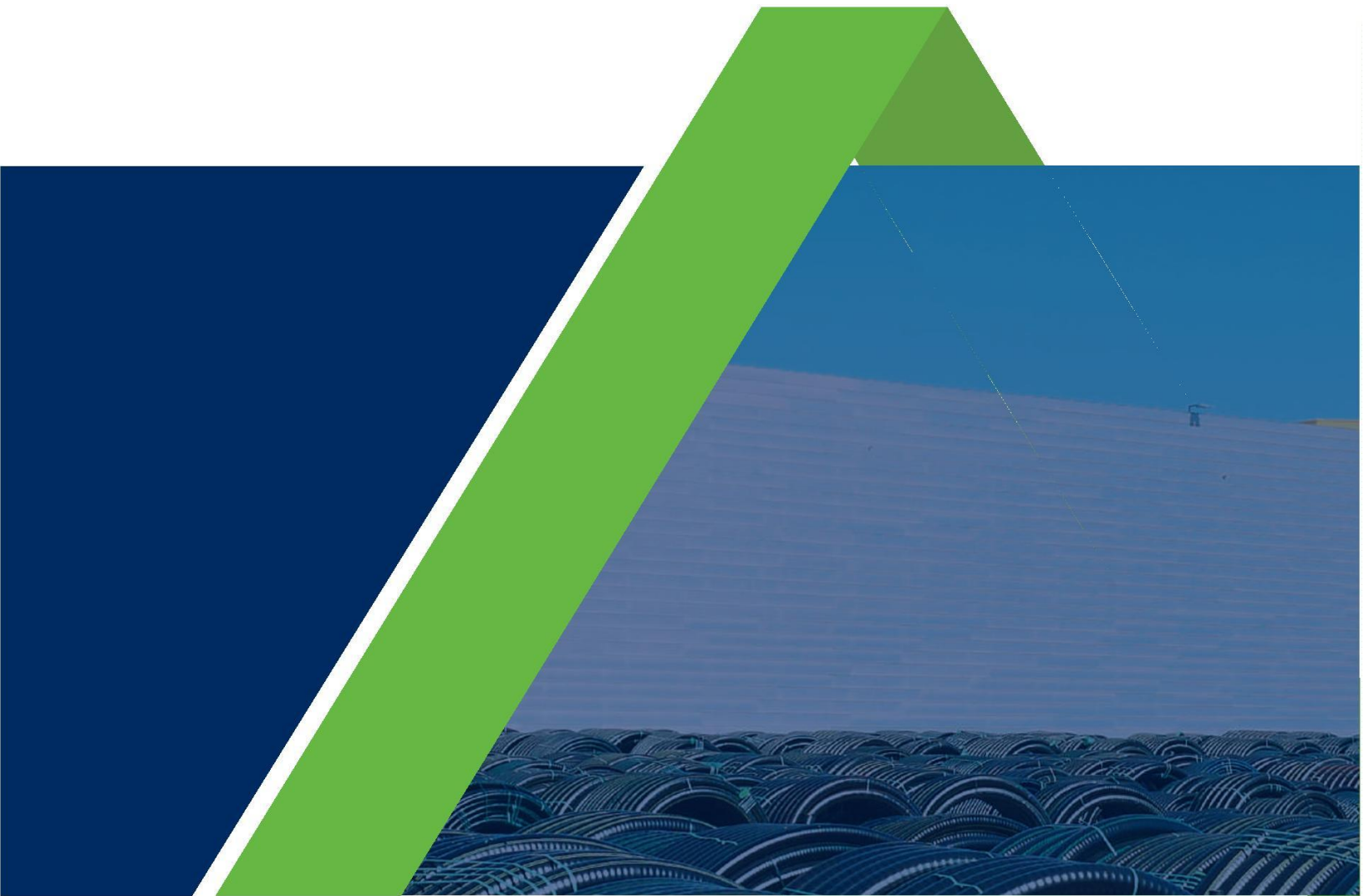

RK Infra Infrastructure GesmbH

Address: Gollensdorf 24,
A-4300 St. Valentin

TEL.: +43 (0) 7435/93080

FAX: +43 (0) 7435/93080-218

E-Mail: office@rkinfracom